



FM Modules

Installation Manual

P/N 400506-03

Revision: A4

Date: June 30, 2005

© Control Techniques Drives Inc. 2001-2005



EMERSON[™]
Industrial Automation

FM-1, FM-2, FM-3, FM-3E, FM-3DN, FM-3PB, FM-4, FM-4E, FM-4DN and FM-4PB Modules Installation Manual



Information furnished by Control Techniques Drives Inc. (Control Techniques) is believed to be accurate and reliable. However, no responsibility is assumed by Control Techniques for its use. Control Techniques reserves the right to change the design or operation of the equipment described herein and any associated motion products without notice. Control Techniques also assumes no responsibility for any errors that may appear in this document. Information in this document is subject to change without notice.

P/N 400506-03

Revision: A4

Date: June 30, 2005

© Control Techniques Drives Inc. 2001-2005

© Control Techniques Drives Inc. 2001-2005

Part Number: 400506-03

Revision: A4

Date: June 2005

Information in this document is subject to change without notice. Companies, names, and data used in examples herein are fictitious unless otherwise noted. No part of this document may be reproduced or transmitted in any form or by any means, electronic or mechanical, for any purpose, without the express written permission of Control Techniques.

The following are trademarks of Control Techniques and may not be reproduced in any fashion without written approval of Control Techniques: EMERSON Motion Control, EMERSON Motion Control PowerTools, AXIMA, "Motion Made Easy."

Control Techniques is a division of EMERSON Co.

Control Techniques Drives, Inc. is not affiliated with Microsoft Corporation, owner of the Microsoft, Windows, and Windows NT trademarks.

This product contains DeviceNet software that is licensed from SST, a Division of Woodhead Limited, 50 Northland Road, Waterloo, Ontario - Canada - N2V 1N3

DeviceNet is a trademark of Open DeviceNet Vendor Association

RS Network and SLC 500 PLC are trademarks of Allen Bradley. Control Techniques Drives Inc. is not affiliated with Allen Bradley.

This document has been prepared to conform to the current released version of the product. Because of our extensive development efforts and our desire to further improve and enhance the product, inconsistencies may exist between the product and documentation in some instances. Call your customer support representative if you encounter an inconsistency.

Customer Support

Control Techniques
12005 Technology Drive
Eden Prairie, Minnesota 55344-3620
U.S.A.

Telephone: (952) 995-8000 or (800) 893-2321

It is Control Techniques' goal to ensure your greatest possible satisfaction with the operation of our products. We are dedicated to providing fast, friendly, and accurate assistance. That is why we offer you so many ways to get the support you need. Whether it's by phone, fax or modem, you can access Control Techniques support information 24 hours a day, seven days a week. Our wide range of services include:

FAX**(952) 995-8099**

You can FAX questions and comments to Control Techniques. Just send a FAX to the number listed above.

Website and Email**www.emersonct.com**

Website: www.emersonct.com

Email: info@emersonct.com

If you have Internet capabilities, you also have access to technical support using our website. The website includes technical notes, frequently asked questions, release notes and other technical documentation. This direct technical support connection lets you request assistance and exchange software files electronically.

Technical Support**(952) 995-8033 or (800) 893-2321**

Email: service@emersonct.com

Control Techniques' "Motion Made Easy" products are backed by a team of professionals who will service your installation. Our technical support center in Eden Prairie, Minnesota is ready to help you solve those occasional problems over the telephone. Our technical support center is available 24 hours a day for emergency service to help speed any problem solving. Also, all hardware replacement parts, if needed, are available through our customer service organization.

When you call, please be at your computer, with your documentation easily available, and be prepared to provide the following information:

- Product version number, found by choosing About from the **Help** menu
- The type of controller or product you are using

- Exact wording of any messages that appear on your screen
- What you were doing when the problem occurred
- How you tried to solve the problem

Need on-site help? Control Techniques provides service, in most cases, the next day. Just call Control Techniques' technical support center when on-site service or maintenance is required.

Training Services

(952) 995-8000 or (800) 893-2321

Email: training@emersonct.com

Control Techniques maintains a highly trained staff of instructors to familiarize customers with Control Techniques' "Motion Made Easy" products and their applications. A number of courses are offered, many of which can be taught in your plant upon request.

Application Engineering

(952) 995-8000 or (800) 893-2321

Email: service@emersonct.com

An experienced staff of factory application engineers provides complete customer support for tough or complex applications. Our engineers offer you a broad base of experience and knowledge of electronic motion control applications.

Customer Service (Sales)

(952) 995-8000 or (800) 893-2321

Email: customer.service@emersonct.com

Authorized Control Techniques distributors may place orders directly with our Customer Service department. Contact the Customer Service department at this number for the distributor nearest you.

Document Conventions

Manual conventions have been established to help you learn to use this manual quickly and easily. As much as possible, these conventions correspond to those found in other Microsoft® Windows® compatible software documentation.

Menu names and options are printed in bold type: the **File** menu.

Dialog box names begin with uppercase letters: the Axis Limits dialog box.

Dialog box field names are in quotes: "Field Name."

Button names are in italic: *OK* button.

Source code is printed in Courier font: `Case ERMS`.

In addition, you will find the following typographic conventions throughout this manual.

This	Represents
bold	Characters that you must type exactly as they appear. For example, if you are directed to type a:setup , you should type all the bold characters exactly as they are printed.
italic	Placeholders for information you must provide. For example, if you are directed to type <i>filename</i> , you should type the actual name for a file instead of the word shown in italic type.
ALL CAPITALS	Directory names, file names, key names, and acronyms.
SMALL CAPS	Non-printable ASCII control characters.
KEY1+KEY2 example: (Alt+F)	A plus sign (+) between key names means to press and hold down the first key while you press the second key.
KEY1,KEY2 example: (Alt,F)	A comma (,) between key names means to press and release the keys one after the other.

Special nomenclature is provided for people working with these products, as follows:

⚠ WARNING

“Warning indicates a potentially hazardous situation which, if not avoided, could result in death or serious injury.

⚠ CAUTION

“Caution” indicates a potentially hazardous situation that, if not avoided, may result in minor or moderate injury.

CAUTION

“Caution” used without the safety alert symbol indicates a potentially hazardous situation that, if not avoided, may result in property damage.

Note

For the purpose of this manual and product, “Note” indicates essential information about the product or the respective part of the manual.

Throughout this manual, the word “drive” refers to an EN or MDS drive.

Safety Instructions

WARNING

General Warning

Failure to follow safe installation guidelines can cause death or serious injury. The voltages used in the product can cause severe electric shock and/or burns and could be lethal. Extreme care is necessary at all times when working with or adjacent to the product. The installation must comply with all relevant safety legislation in the country of use.

Qualified Person

For the purpose of this manual and product, a “qualified person” is one who is familiar with the installation, construction and operation of the equipment and the hazards involved. In addition, this individual has the following qualifications:

- Is trained and authorized to energize, de-energize, clear and ground and tag circuits and equipment in accordance with established safety practices.
- Is trained in the proper care and use of protective equipment in accordance with established safety practices.
- Is trained in rendering first aid.

Reference Materials

The following related reference and installation manuals may be useful with your particular system.

- *Epsilon Eb and E Series EN Drives Reference Manual* (400501-01)
- *MDS Reference Manual* (400525-01)
- *PowerTools Software User’s Guide* (400503-01)
- *FM-1 Speed Module Reference Manual* (400506-01)
- *FM-2 Indexing Module Reference Manual* (400507-01)
- *FM-3 Programming Module Reference Manual* (400508-01)
- *FM-4 Programming Module Reference Manual* (400509-01)
- *FM-3 and FM-4 Connectivity Modules Reference Manual* (400508-04)

Safety Considerations

Safety Precautions

This product is intended for professional integration into a complete system. If you install the product incorrectly, it may present a safety hazard. The product and system may use high voltages and currents, carry a high level of stored electrical energy, or control mechanical equipment that can cause injury.

You should give close attention to the electrical installation and system design to avoid hazards either in normal operation or in the event of equipment malfunction. System design, installation, commissioning and maintenance must be carried out by personnel who have the necessary training and experience. Read and follow this safety information and the instruction manual carefully.

Enclosure

This product is intended to be mounted in an enclosure which prevents access except by trained and authorized personnel, and which prevents the ingress of contamination. This product is designed for use in an environment classified as pollution degree 2 in accordance with IEC664-1. This means that only dry, non-conducting contamination is acceptable.

Setup, Commissioning and Maintenance

It is essential that you give careful consideration to changes to drive settings. Depending on the application, a change could have an impact on safety. You must take appropriate precautions against inadvertent changes or tampering. Restoring default parameters in certain applications may cause unpredictable or hazardous operation.

Safety of Machinery

Within the European Union all machinery with which this product is used must comply with Directive 89/392/EEC, Safety of Machinery.

The product has been designed and tested to a high standard, and failures are very unlikely. However the level of integrity offered by the product's control function – for example stop/start, forward/reverse and maximum speed – is not sufficient for use in safety-critical applications without additional independent channels of protection. All applications where malfunction could cause injury or loss of life must be subject to a risk assessment, and further protection provided where needed.

⚠ WARNING

General warning

Failure to follow safe installation guidelines can cause death or serious injury. The voltages used in this unit can cause severe electric shock and/or burns, and could be lethal. Extreme care is necessary at all times when working with or adjacent to this equipment. The installation must comply with all relevant safety legislation in the country of use.

AC supply isolation device

The AC supply must be removed from the EN drive and Power Module Backplane using an approved isolation device or disconnect before any servicing work is performed, removing and/or installing the Power Module and /or Drive Module(s), other than adjustments to the settings or parameters specified in the manual. The drive contains capacitors which remain charged to a potentially lethal voltage after the supply has been removed. Allow at least 3 minutes for MDS and Epsilon, 30 seconds for EN drives after removing the supply before carrying out any work which may involve contact with electrical connections to the drive.

Products connected by plug and socket

A special hazard may exist where the drive is incorporated into a product which is connected to the AC supply by a plug and socket. When unplugged, the pins of the plug may be connected to the drive input, which is only separated from the charge stored in the bus capacitor by semiconductor devices. To avoid any possibility of electric shock from the pins, if they are accessible, a means must be provided for automatically disconnecting the plug from the drive (that is, a latching contactor).

Grounding (Earthing, equipotential bonding)

The drive must be grounded by a conductor sufficient to carry all possible fault current in the event of a fault. The ground connections shown in the manual must be followed.

Fuses

Fuses or over-current protection must be provided at the input in accordance with the instructions in the manual.

Isolation of control circuits

The installer must ensure that the external control circuits are isolated from human contact by at least one layer of insulation rated for use at the applied AC supply voltage.

Table of Contents

Safety Considerations	vii
Introduction	1
Installation (All FMs)	7
Basic Installation Notes	7
Mechanical Installation	7
Electrical Installation	8
Software Installation	10
Starting and Exiting PowerTools Software	12
Accessing Help	13
DeviceNet Installation (FM-3DN and FM-4DN only)	15
Basic Installation Notes	15
Wiring	15
Changing the MacID and BaudRate	17
Profibus Installation (FM-3PB and FM-4PB only)	19
Mechanical Installation	19
Electrical Installation	20
Ethernet Installation (FM-3E and FM-4E only)	23
Basic Installation Notes	23
Wiring	23
Changing the IP Address, Subnet Mask and Gateway	24
Diagnostics and Troubleshooting (All FMs)	27
Diagnostic Display	27
Fault Codes	28
Drive Faults	34
Error Messages	35

Online Status Indicators 40

Specifications (All FMs) 45

Dimensions and Clearances 46

Cable Diagrams 48

Sync Cable Diagrams (All FM-3 and FM-4 Models) 58

Index 63

Introduction

The Function Module (FM) is a compact and rugged module that attaches to the front of the EN drive and the MDS drive module. It provides eight digital input lines and four digital output lines, in addition to the four input and three output lines available on the drive.

The FM-1 Speed Module offers the user eight digital Torque presets, two additional Summation modes, and an Alternate Operating mode.

The FM-2 Indexing Module enables the user to initiate up to 16 different indexes, jogging, and a single home routine.

The FM-3, FM-3E, FM-3PB and FM-3DN Programming Modules offer complex motion profiling. A complex motion profile consists of two or more indexes that are executed in sequence such that the final velocity of each index except the last is non-zero. Logical instructions between index statements can provide a powerful tool for altering motion profiles 'on the fly'.

The FM-4, FM-4E, FM-4PB and FM-4DN Programming Modules offer complex motion profiling, along with multi-tasking user programs. A complex motion profile consists of two or more indexes that are executed in sequence such that the final velocity of each index except the last is non-zero. Logical instructions between index statements can provide a powerful tool for altering motion profiles 'on the fly'.

The FM modules define complex motion by a configuration file that includes setups and function assignments. For the FM-3 and FM-4 modules, the configuration file also includes programs. The configuration file is created using PowerTools software. The FM-1 and FM-2 modules use PowerTools-FM software, and the FM-3, FM-3E, FM-3PB, FM-3DN, FM-4, FM-4E, FM-4PB and FM-4DN modules use PowerTools Pro software. Setup views have the same look and feel as dialog boxes. The wiring of input and output functions is done through assignments in the software. PowerTools software is an easy-to-use Microsoft® Windows® based setup and diagnostics tool.

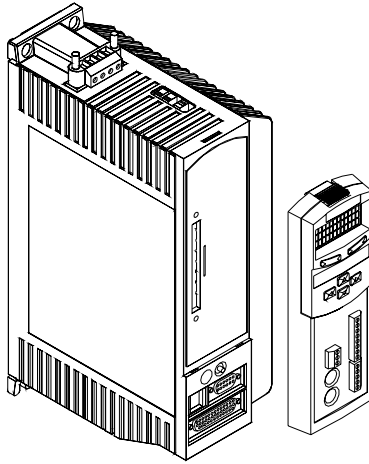

Figure 1: EN Drive with FM Module

Note that the drive's firmware is disabled whenever a FM module is attached. Therefore, if the drive's hardware is FM compatible, then the drive's firmware can be any version because the programming features reside in the function module's flash memory. Flash files used for firmware upgrades are available on the Control Techniques website.

The FM module stores drive setup parameters within the module itself. This allows you to transfer the FM module to another drive of the same model without losing setup parameters.

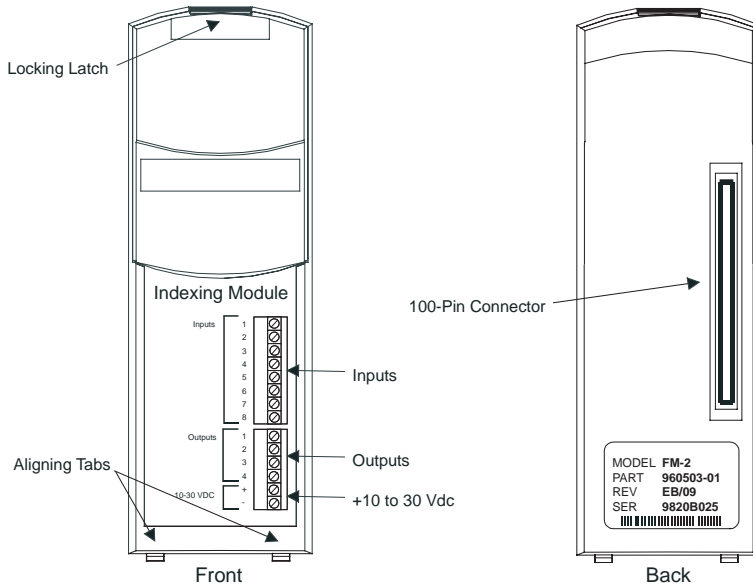

Figure 2: FM-1 and FM-2 Module Features (FM-2 module shown)

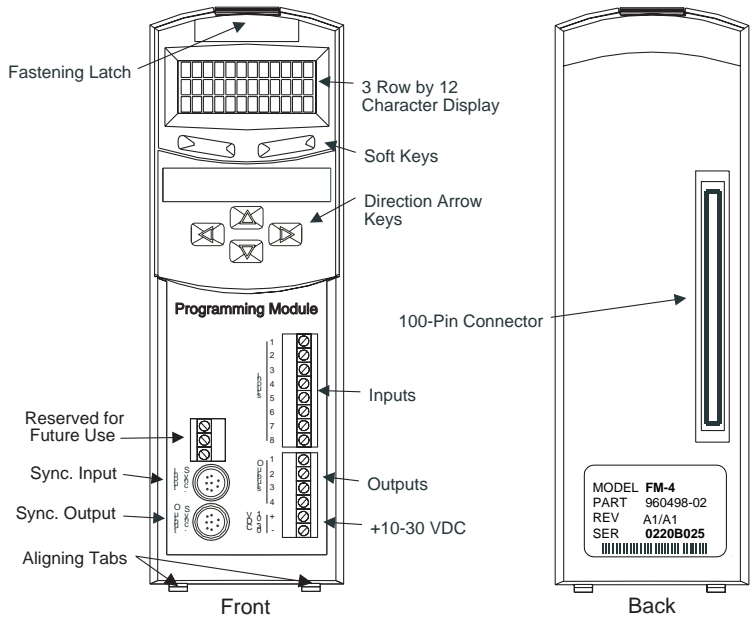

Figure 3: FM-3 and FM-4 Module Features (FM-4 Module shown)

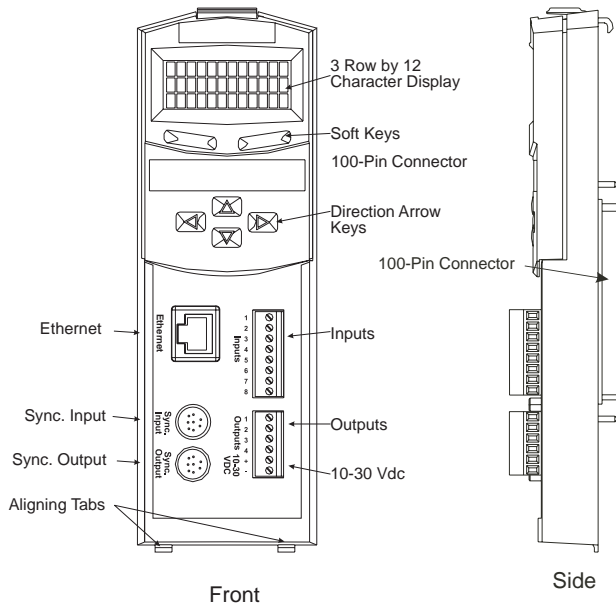

Figure 4: FM-3E and FM-4E EtherNet Module Features

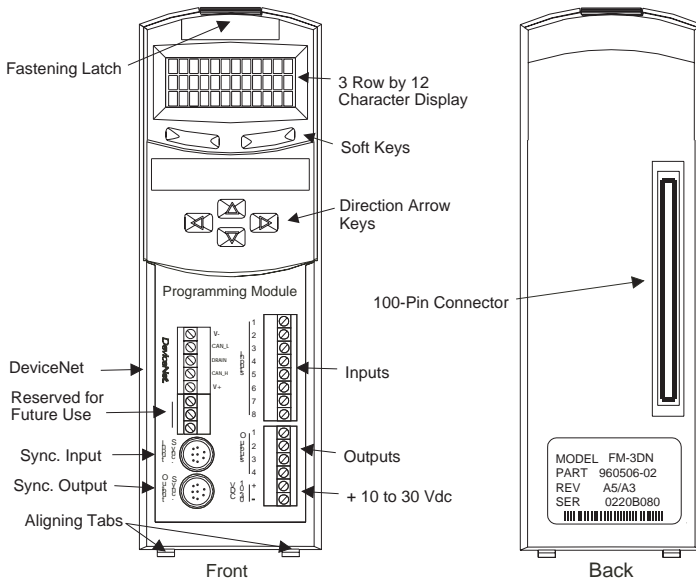

Figure 5: FM-3DN and FM-4DN DeviceNet Module Features

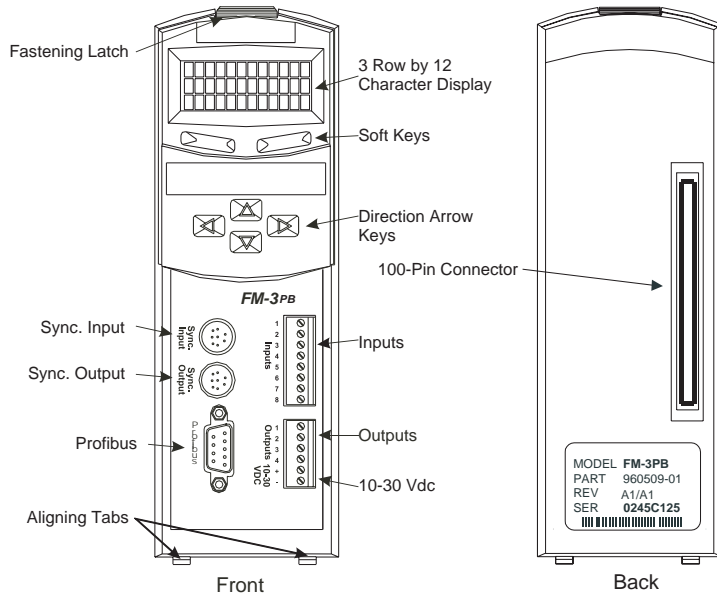

Figure 6: FM-3PB and FM-4PB Profibus Module Features

Installation (All FMs)

Basic Installation Notes

You are required to follow all safety precautions during startup, such as providing proper equipment grounding, correctly fused power and an effective Emergency Stop circuit which can immediately remove power in the case of a malfunction. See the “Safety Considerations” section for more information.

Mechanical Installation

The FM module detects and verifies the drive serial number when it's attached to the drive. If a FM module is moved from one drive to another, it will detect the difference in serial numbers and generate an Invalid Configuration fault (indicated by "U" on the keypad display). To remove an "U" fault simply hold the drive reset button for 12 or more seconds.

Two aligning tabs, a locking latch and a 100-pin connector are used to attach the FM module to the drive. All electrical connections between the FM module and the drive are accomplished with the single connector located on the rear of the FM module.

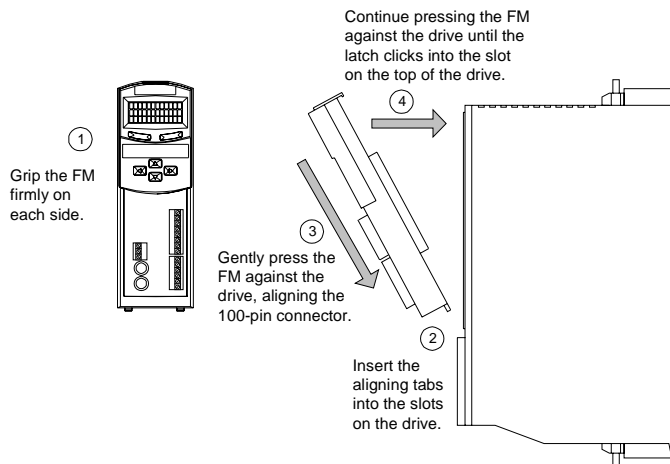

Figure 7: Attaching the FM Module to an E Series Drive (FM-3 shown)

CAUTION

Do not attach or detach the FM module when power is applied to the drive. It could cause drive instability and may cause property damage.

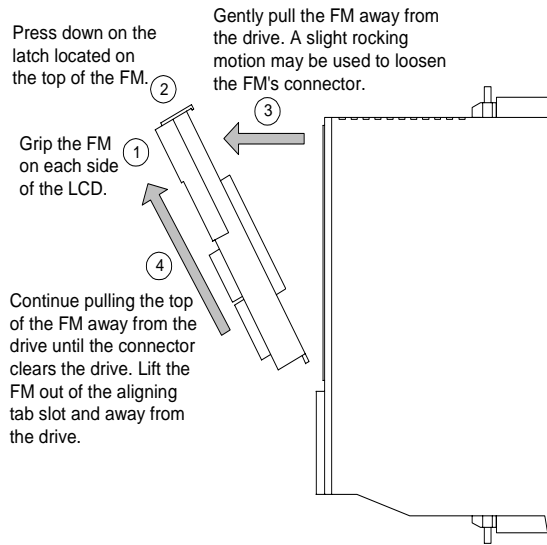

Figure 8: Detaching the FM Module from the Drive Connections

CAUTION

Do not attach or detach the FM module when power is applied to the drive. It could cause drive instability and may cause property damage.

Electrical Installation

Input/Output Wiring

The FM Modules are equipped with eight optically isolated input lines and four optically isolated output lines. They are designed to operate from a +10 Vdc to 30 Vdc source. All inputs and outputs are configured as sourcing. The user is responsible for choosing a load that will limit each output current to less than 200 mA.

The input lines, output lines and I/O power connectors are on removable terminal blocks. 18 to 24 AWG stranded wire is recommended.

A single power supply can be used to power the I/O on both the drive and the FM Module, however, it must be wired to both the drive and the FM Module because I/O power is not passed through the connector on the back of the FM Module. Alternatively, separate power supplies can be used to power the I/O on the drive and the FM Module, as long as they share a common ground.

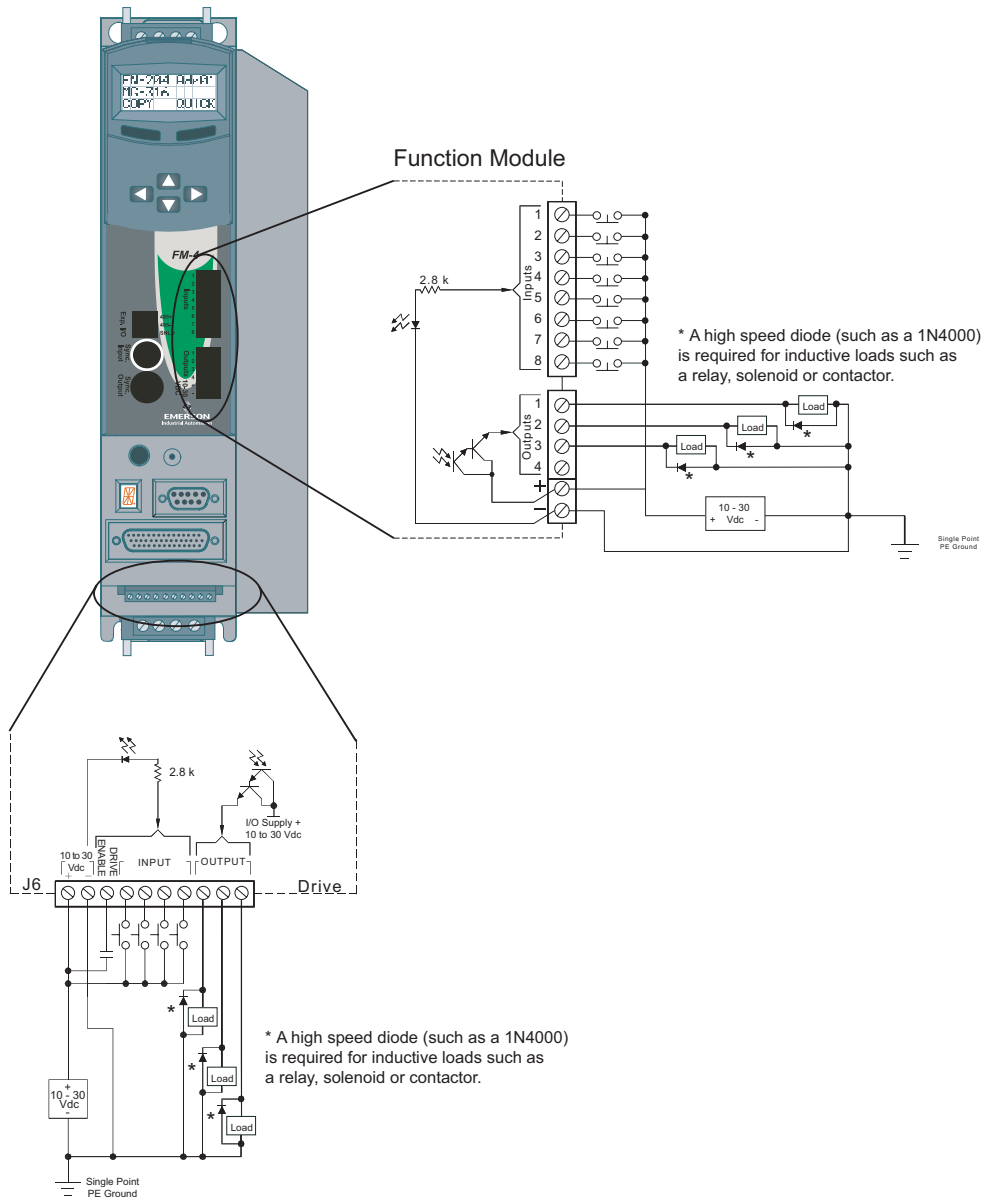

Figure 9: Input/Output Sourcing Wiring Diagram (FM-4 module/EN drive shown)

For more information about wiring and cables, please refer to the reference manual for the specific FM module.

Modbus Communications

The drive's serial communication protocol is Modbus RTU slave with a 32 bit data extension. The Modbus protocol is available on most operator interface panels and PLC's.

Serial Communications Specifications	
Max baud rate	19.2k (default)
Start bit	1
Stop bit	2
Parity	none
Data	8

Control Techniques' Motion Interface panels are supplied with a Modbus master communications driver.

Software Installation

PowerTools-FM and PowerTools Pro software was designed for users who need access to all setup options and diagnostic information for the drive. The software provides access to all commonly used drive parameters.

PC System Configuration

Required:

- Microsoft® Windows® 98, Microsoft® Windows NT® 4.0 (service pack 3), Microsoft® Windows 2000, and Microsoft® Windows XP (Home and Pro)
- Serial port
- Mouse
- CD-ROM drive
- Microsoft® Internet Explorer v 4.0 or greater

Recommended:

- 16 MB or more RAM for Windows 98, and 32 MB or more for Windows NT and Windows 2000 and 64MB or more for Windows XP.
- Up to 45 MB of hard disk space required for a full installation; 15 MB for minimum installation.

Optional:

- Windows-compatible printer
- Modem and Internet access

Preparing for PowerTools Installation

- Close all programs and turn off virus protection software to prevent installation conflicts.
- If you have another version of PowerTools on your computer and do not want to overwrite that version, change the default installation folder for PowerTools during installation setup.
- To avoid overwriting programs you have customized or created, place them into a separate folder before you install.

Installing PowerTools Software

You must be running Microsoft Windows 98, Microsoft Windows NT 4.0, Microsoft Windows 2000 or Microsoft Windows XP to install this software.

1. Insert the Control Techniques Power CD into the CD-ROM drive. Navigate to the PowerTools-FM or PowerTools Pro installation link.

OR

If installing from the website, when prompted, save the software to your hard drive. Use Windows Explorer, navigate to the PTFM.exe or PTPro.exe file which is now on your hard drive. Then, double click on the PTFM.exe or PTPro.exe file.

2. Click the *OK* button, then follow the instructions on your screen.

Installation will take a few minutes. The install program automatically:

- Creates the directory on your hard drive named either:
 C:\Control Techniques\PT-FM
 or
 C:\Control Techniques\PowerTools Pro - (version#)
- Creates a new Windows group called Control Techniques.
- Loads PowerTools into the Control Techniques\PowerTools-FM or Control Techniques\PowerTools Pro - vX.XX directory.

Note

To complete the installation for Windows 98, NT and 2000, you may be required to restart Windows.

Refer to the readme.txt file located at the end of the installation for more information.

If You Need Help with Installation

If you encounter problems while installing PowerTools software, call Technical Support at (952) 995-8033 or (800) 893-2321 (24 hour assistance).

Starting and Exiting PowerTools Software

Starting the Software

1. Click the Start button on the taskbar at the bottom left of the screen.



2. Click on the Programs selection. The Programs menu appears.



3. Click on the “Control Techniques” folder icon.



4. Click on the “PowerTools” folder icon.

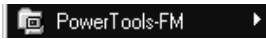

or



5. Click on the PowerTools program icon.

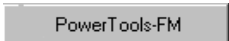

or



Opening a New File

To start a new file or configuration, select **File** from the menu bar, and then select **New**. You may also click on the File New button on the toolbar.

The New dialog box will appear prompting the user to select the Drive Setup pertinent to the FM module in use.

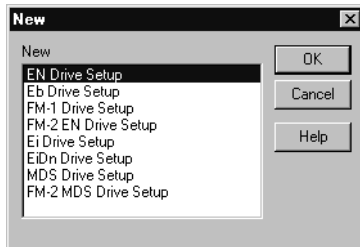

Figure 10: PowerTools-FM New Configuration Dialog Box

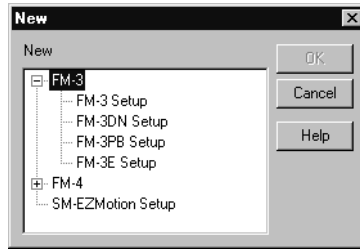

Figure 11: PowerTools Pro New Configuration Dialog Box

Note

If the module is DeviceNet compatible (FM-3DN or FM-4DN printed on front panel), then select FM-3DN or FM-4DN Drive Setup. If the module is Profibus compatible (FM-3PB or FM-4PB printed on front panel) then select FM-3PB or FM-4PB Drive Setup. If the module is EtherNet compatible (FM-3E or FM-4E printed on front panel), then select FM-3E or FM-4E Drive Setup. If the module is intended solely for Modbus communications (FM-3 or FM-4 printed on front panel), then select FM-3 or FM-4 Drive Setup.

This will create a new file in which you will construct the entire FM module setup.

Exiting the Software

Choose **File** from the menubar, then click **Exit**. If you are using the keyboard, press the shortcut key combination Alt+F, X.

If you made changes, PowerTools displays an Alert dialog box asking whether you want to save your current work. Click the *Yes* button or press Enter to save your work, or click the *No* button to quit without saving.

Accessing Help

All PowerTools views and dialog boxes provide a *Help* button. This retrieves help for that particular subject and provides details to assist you in the use of each view or dialog box. Also, provided is a index-based help system. There is the ability to search the online help using a keyword. Lastly, PowerTools has context sensitive help capability.

Online Help displays detailed procedural and reference information. It contains some information that does not appear in this manual.

To display Help in PowerTools, do one of the following:

- Press F1.

- Choose a command from the Help menu.
- Click the *Help* button on a dialog box or view.
- Click the Help button on the toolbar.
- Click the Context Sensitive Help button on the toolbar and then click on the field in the view.

DeviceNet Installation (FM-3DN and FM-4DN only)

Basic Installation Notes

You are required to follow all safety precautions during start-up, such as providing proper equipment grounding, correctly fused power and an effective Emergency Stop circuit which can immediately remove power in the case of a malfunction. See the “Safety Considerations” section for more information.

Wiring

The DeviceNet wiring for the FM-3DN and FM-4DN modules follow the ODVA standard documented in the DeviceNet Specification Volume II.

Wire Locations	Wire Colors
V-	Black
Can_L	Blue
Drain	
Can_H	White
V+	Red

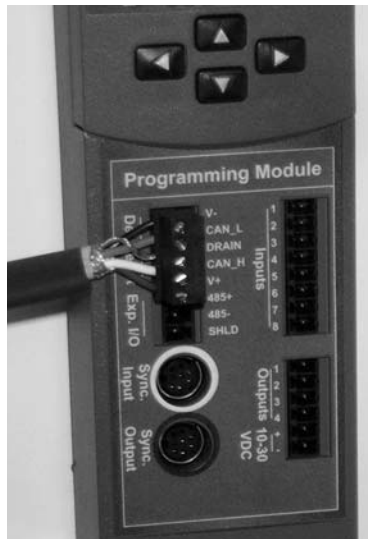

Figure 12: DeviceNet Wiring Connection

The FM-3DN and FM-4DN modules support both Multi-Tap and Multi-Drop (Daisy Chaining) wiring configurations. Figures 13 and 14 show typical configurations.

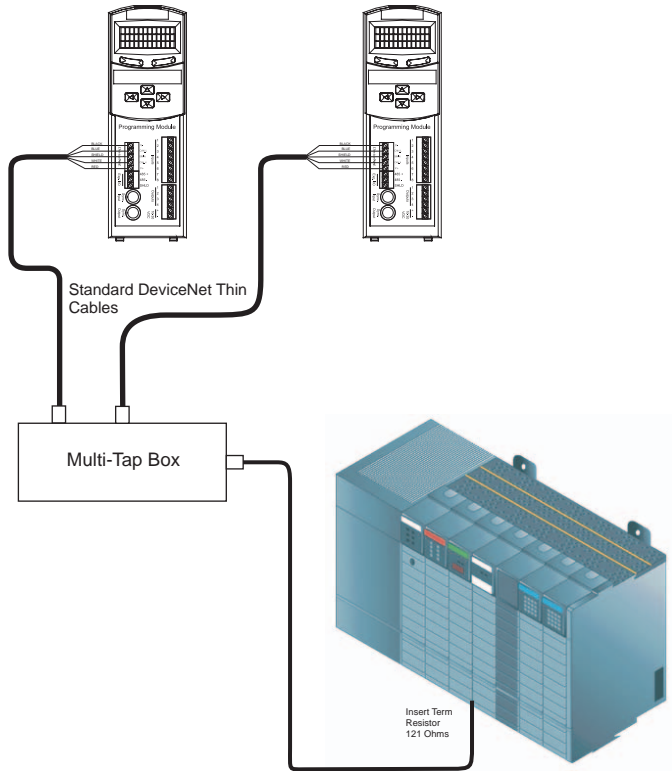

Figure 13: Multi-Tap DeviceNet Configuration and Wiring

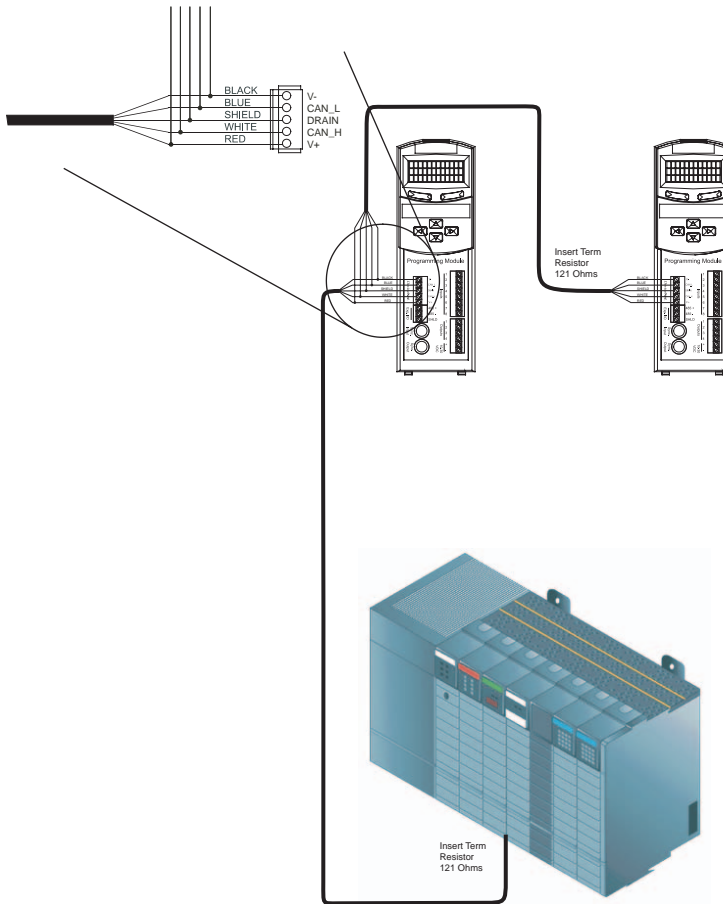

Figure 14: Multi-Drop DeviceNet Configuration and Wiring

Changing the MacID and BaudRate

MacID and BaudRate can be changed on the keypad on the front of the FM Module.

1. Use the soft key under menu and the arrow keys on the keypad to scroll through the menu to DVNet. Select it.
2. Scroll through the parameters with the up and down arrows.
 - a. To change the MacID, scroll to MacID; click modify; use the up and down arrows to change the setting; click OK.

b. To change the BaudRate, scroll to BaudRate; click modify; use the up and down arrows to change the setting; click ok. After a BaudRate change, cycle the power to the drive.

BaudRate and MacID can also be changed through the DeviceNet View in PowerTools Pro software. See *FM-3 and FM-4 Connectivity Reference Manual* (P/N 400508-04) for more information.

Profibus Installation (FM-3PB and FM-4PB only)

Mechanical Installation

Follow the instructions for mechanical installation of an EN and FM-3 as detailed in the *EN-Series Installation Manual* (P/N 400501-02).

Profibus Hardware Components

The following components are necessary to design a Profibus communications system: cables, Nodes/devices, Connectors, Power Supplies, Terminating resistors.

- Cables: Profibus cabling consists of a 2 wire twisted pair with a braided shield. Control Techniques offers this cable as model number PBC CABLE-xxx.

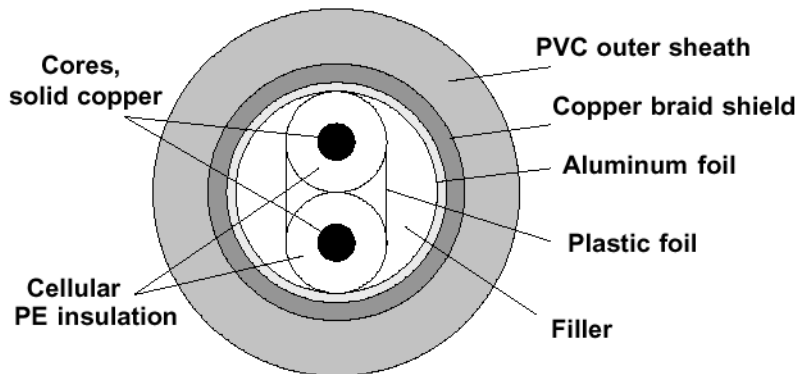

Figure 15: Cross-sectional view of the PBC Cable-XXX

- Nodes/Devices: A Profibus node is any device that is addressable through Profibus Media and contains Profibus communications circuitry. Profibus Slaves must comply with the following: Slaves must be Profibus-compatible devices. 126 Slaves can be supported on one network. Each Slave must be assigned a unique Profibus node address.
- Connectors: Due to the high speed nature of the Profibus network, the recommended connector is a 35 degree Siemens Profibus Connector. Control Techniques offers this connector as model number PBCONN.

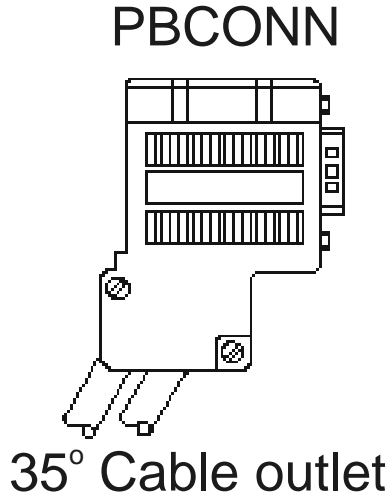

Figure 16: Recommended Connector for Profibus Communications

- Terminating Resistors:** Terminating resistors are used to reduce the reflection of signals over the network. Due to the high bit rates of Profibus, terminating resistors must be used at both ends of the network in order to guarantee communications stability. When using the Profibus connector offered by Control Techniques, the terminating resistor is built into the connector and is turned on when the red switch on the back of the connector is turned to the “on” position. When not using this connector (not recommended) terminating resistors of 220 ohms must be installed between A and B.

Electrical Installation

Physical Connections to the Profibus Network: A two wire configuration is used to connect the FM-3/4PB to the Profibus network. When multiple FM-3/4PB nodes are connected to the network, connectors will be daisy chained by making use of the incoming and outgoing lines.

Pin Number	Name	Insulation Color	Direction
8	A1	Green	Incoming
3	B1	Red	Incoming
8	A2	Green	Outgoing
3	B2	Red	Outgoing

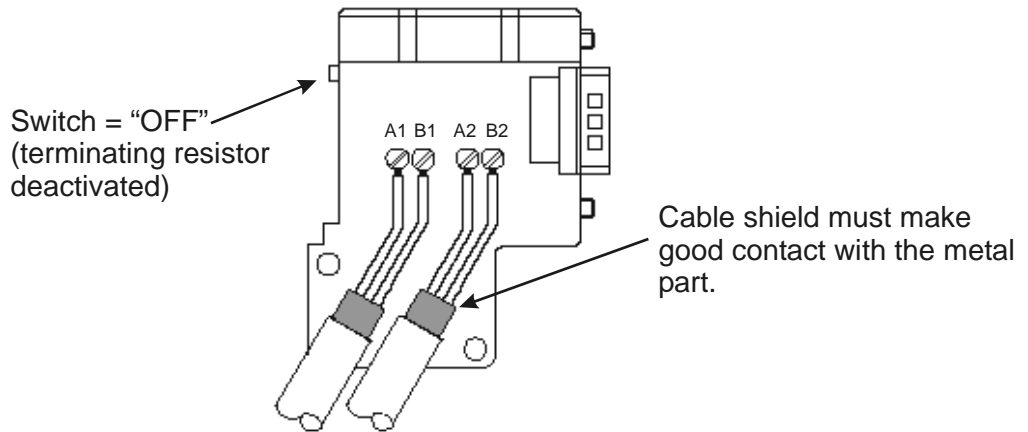

Figure 17: Connector Wiring

The connector provided for Profibus is a standard DB9 female connector.

Ethernet Installation (FM-3E and FM-4E only)

Basic Installation Notes

You are required to follow all safety precautions during start-up, such as providing proper equipment grounding, correctly fused power and an effective Emergency Stop circuit which can immediately remove power in the case of a malfunction. See the “Safety Considerations” section for more information.

Wiring

The Ethernet wiring uses a category 5 cable (Control Techniques’ model# ETH-PATCH-xxx) and follows the Ethernet/IP specification.

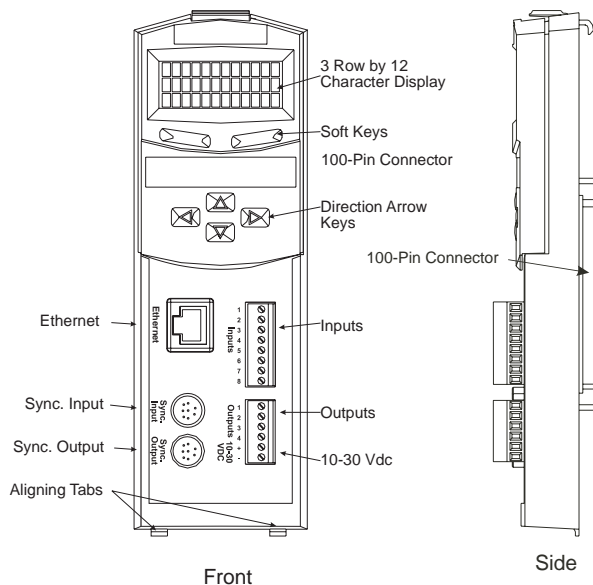

Figure 18: Ethernet Module Connections

The FM-3E and FM-4E modules support both Switch and Hub wiring configuration. Figure 19 show a typical configuration.

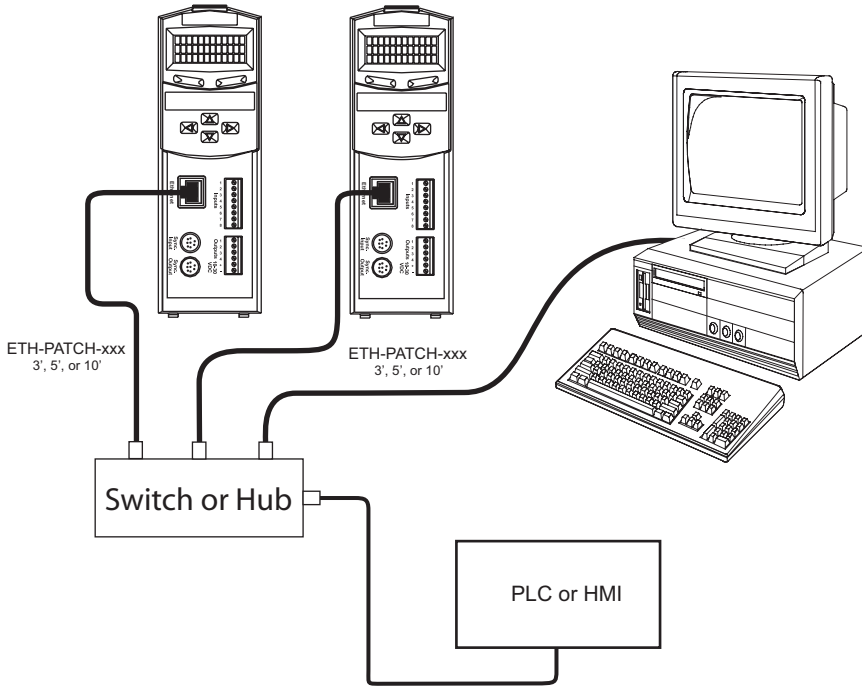

Figure 19: Multi-Tap Ethernet Configuration and Wiring

Changing the IP Address, Subnet Mask and Gateway

Keypad Interface

Like all of the standard FM-3 and FM-4 module parameters, discussed in the “Operational Overview” chapter of the *FM-3 Programming Module Reference Manual* (P/N 400508-01) and *FM-4 Programming Module Reference Manual* (P/N 400509-01), the Ethernet system parameters can be edited from the keypad display (LCD) on the front of the FM-3E or FM-4E module. The keypad on the front of the FM-3E and FM-4E module provides navigation through a menu of common parameters and displays current functions. Navigation through the menu is accomplished with the six keys located below the display. The top two keys are called the “soft keys” because they relate to the commands located directly above each key on the display. These keys are used to select the operation (i.e. Modify, Ok, Cancel), parameter group, and/or to validate information. The four arrow keys are used to navigate

through parameter groups, select a specific parameter to be modified, and to modify digital and numeric data.

The operation of the arrow keys is dependent upon the type of parameter which is being modified.

Software







The IP Address, Subnet Mask and Gateway can also be changed on the Setup view in PowerTools Pro.









Diagnosics and Troubleshooting (All FMs)

Diagnostic Display

The diagnostic segment display on the front of the drive shows drive status, FM module status, and fault codes. When a fault condition occurs, the drive will display the fault code, overriding the status code. The alphanumeric display on the FM module provides additional fault information.

The decimal point is “On” when the drive is enabled, and the stop input is not active. This indicates that the drive is ready to run and any motion command will cause motion. Motion commands will not cause motion unless you are Ready (R) and the decimal point is “On”.

Display Indication	Status	Description	FM-3/FM-4 Keypad Display	Applicable FM Module
	Brake Engaged (Output "Off")	Motor brake is mechanically engaged. this character will only appear if the Brake Output function is assigned to an output line.	N/A	FM-1, FM-2
	Ready	The FM module and drive system is functioning normally and is ready to execute a motion command.	Drive Type Address Motor Type Menu Groups	All
	Disabled	Power Stage is disabled.	Drive Type Address Motor Type Menu Groups	All
	RMS Foldback	Motor torque is limited to 80 percent.	Drive Type Address Motor Type Menu Groups	All
	Stall Foldback	Drive output current is limited to 80 percent of drive stall current.	Drive Type Address Motor Type Menu Groups	All
	Ready to Run	Drive enabled. No stop input.	Drive Type Address Motor Type Menu Groups	All

Display Indication	Status	Description	FM-3/FM-4 Keypad Display	Applicable FM Module
	Homing	Home is executing.	Drive Type Motor Type Menu Groups Address	FM-2, FM-3, FM-3DN, FM-3PB, FM-4, FM-4DN, FM-4PB
	Indexing	Index is executing.	Drive Type Motor Type Menu Groups Address	FM-2, FM-3, FM-3DN, FM-3PB, FM-4, FM-4DN, FM-4PB
	Jogging	Jog is executing.	Drive Type Motor Type Menu Groups Address	FM-2, FM-3, FM-3DN, FM-3PB, FM-4, FM-4DN, FM-4PB
	Position	Waiting for command (Pulse mode).	N/A	FM-1
	Program	Program is executing.	Drive Type Motor Type Menu Groups Address	FM-3, FM-3DN, FM-3PB, FM-4, FM-4DN, FM-4PB
	Velocity	Velocity mode operation	N/A	FM-1
	Torque	Torque mode operation	N/A	FM-1
	Summation	Summation mode operation	N/A	FM-1
	Stop or Travel Limit Decel	Stop or Travel Limit Decel in progress.	N/A	FM-2









Fault Codes











A number of diagnostic and fault detection circuits are incorporated to protect the drive. Some faults, such as high DC bus and amplifier or motor over temperature can be reset with the Reset button on the front of the drive or the Reset input function. Other faults, such as encoder

faults, can only be reset by cycling power “Off” (wait until the diagnostics display turns “Off”), then turning power “On”.

The drive accurately tracks motor position during fault conditions. For example, if there is a "Low DC Bus" fault when the power stage is disabled, the drive will continue to track the motor’s position provided the logic power is not interrupted.

The +/- Limit faults are automatically cleared when the fault condition is removed. The table below lists all the fault codes in priority order from highest to lowest. This means that if two faults are active, only the higher priority fault will be displayed.

Segment Display	Fault	Action to Reset	Bridge Disabled	FM-3/FM-4 Display	Applicable FM Module
	Flash Invalid	Reprogram the FM’s Flash	Yes		All
	Power Up Test	Cycle Power	Yes	Power Up Tst	All
	NVM Invalid	Reset Button or Input line	Yes	NVM Invalid	All
	Invalid Configuration	Reset Button or Input line	Yes	Invalid Conf	All
	Power Module	Reset Button or Input line	Yes	Power Module	All
	High DC Bus	Reset Button or Input line	Yes	High DC Bus	All
	Low DC Bus	Reset Button or Input line	Yes	Low DCBus	All
	Encoder State	Cycle Power	Yes	Encoder State	All

Segment Display	Fault	Action to Reset	Bridge Disabled	FM-3/FM-4 Display	Applicable FM Module
	Encoder Hardware	Cycle Power	Yes	Encoder HW	All
	Motor Overtemp	Allow motor to cool down, Reset Button or Input line	Yes	MotorOvrTemp	All
	RMS Shunt Power	Reset Button or Input line	Yes	RMS ShuntPowr	All
	Overspeed	Reset Button or Input line	Yes	Over Speed	All
	Max Following Error	Reset Button or Input line	Yes	Following Err	All
	Travel Limit +/-	Auto	No	TravLmtMinus TravLmtPlus	All
	All "On"	Normally on for one second during power up	Yes		All
	FM-3	Reset Button or Input line	Yes	** Fault ** <Fault Description>	FM-3, FM-3DN, FM-3PB
	FM-4	Reset Button or Input line	Yes	** Fault ** <Fault Description>	FM-4, FM-4DN, FM-4PB
	DeviceNet or Profibus	Reset Button	Dependent on Fault	** Fault ** <Fault Description>	FM-3DN, FM-4DN, FM-3PB, FM-4PB

Fault Descriptions

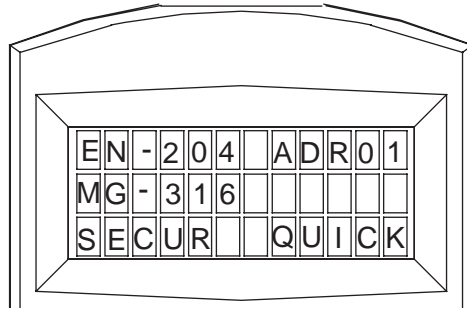

Figure 20: FM-3 and FM-4 Module display is used to display drive and FM faults



Flash Invalid

This fault indicates that the firmware checksum has failed. Use the Tools> Program> Flash menu item from PowerTools software to reprogram/upgrade the firmware stored in flash memory. If this problem persists, call Control Techniques. A common cause would be an interrupted F/W Flash upgrade (cable disconnected during an upgrade process).



Power Up Test

This fault indicates that the power-up self-test has failed. This fault cannot be reset with the reset command or reset button.



NVM Invalid

At power-up, the drive tests the integrity of the non-volatile memory. This fault is generated if the contents of the non-volatile memory are invalid.



Invalid Configuration

The FM was not on this drive during its previous power-up and it is not known if the setup data in the FM matches the drive and motor to which the FM is now attached.

This can also happen when a FM is removed from a drive and the drive is powered-up.

To reset the fault, create or open a configuration file with the correct drive and motor selections and download the configuration to the FM or drive. If you are certain that the setup data in the FM or drive matches the system configuration, press and hold the drive's Reset button for 10 seconds (until the fault is cleared).

⚠ CAUTION

Drive instability and resultant property damage may occur to the drive, motor or both if the fault is cleared using the Reset button when the setup data in the FM does not match the current drive and motor.

Z Power Module

This fault is generated when a power stage over-temperature, over-current or loss of power stage logic supply occurs. This can be the result of a motor short to ground, a short in the motor windings, a motor cable short or the failure of a switching transistor.

It can also occur if the drive enable input is cycled "Off" and "On" rapidly (>10 Hz).

H High DC Bus

This fault will occur whenever the voltage on the DC bus exceeds 440 VDC. The most likely cause of this fault would be an open shunt fuse, a high AC line condition or an application that requires an external shunt (that is, a large load with rapid deceleration).

L Low DC Bus

This fault will occur whenever the voltage on the DC bus drops below 96 volts. The most likely cause of this fault is a reduction (or loss) of AC power. A 50 ms debounce time is used with this fault to avoid faults caused by intermittent power disruption.

E Encoder State

Certain encoder states and state transitions are invalid and will cause the drive to report an encoder state fault. This is usually the result of noisy encoder feedback caused by poor shielding.

E Encoder Hardware

If any pair of encoder lines are in the same state, an encoder line fault is generated. The most likely cause is a missing or bad encoder connection.

M Motor Overtemp

This fault is generated when the motor thermal switch is open due to motor over-temperature or incorrect wiring.

**RMS Shunt Power**

This fault is generated when RMS shunt power dissipation is greater than the design rating of the internal shunt.

**Overspeed**

This fault occurs when the actual motor speed exceeds the Overspeed Velocity Limit parameter. This parameter can be accessed with PowerTools Pro software.

**Max Following Error**

This fault is generated when the following error exceeds the following error limit (default following error limit is .2 revs). With PowerTools Pro you can change the Following Error Limit value on disable in the Position view.

**Travel Limit +/-**

This fault is caused when either the + or - Travel Limit input function is active.

**All "On"**

This is a normal condition during power up of the drive. It will last for less than 1 second. If this display persists, call Control Techniques for service advice.

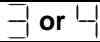
**FM-3 or FM-4 Fault**

A 3 or a 4, as appropriate, will be displayed in the segment display on the drive when the FM experiences one of the following faults.

Traj Fault

This fault occurs when the drive has received trajectory data from the FM module that indicates a problem. Check the user units, velocities, accels and decels for correct values.

No Prog

This fault will be displayed on initial power-up indicating that no configuration has been downloaded to the FM module. To clear the fault, download a valid configuration to the FM module.

OutofSync

This fault is generated when the system is out of sync. To correct it, press the reset button and check the configuration.

ProgramFault

This fault indicates an FM-3 or FM-4 user program fault. For example the program is attempting to divide by zero, or overflows and math errors caused by numbers that are too large, or non-existing parameters.

ProgramInvalid

The user program in flash memory will not run. Download the User Program again using PowerTools Pro. A common cause of this problem could be an interrupted configuration download, such as a cable being disconnected during a download.



DeviceNet or Profibus Fault

This fault indicates a failure in the DeviceNet or Profibus network. This fault could be caused by a major unrecoverable, minor unrecoverable, or major recoverable. Major faults disable the bridge; minor faults do not disable the bridge and will clear themselves after a timed period. The particular error will be displayed on the FM module keypad display.

Drive Faults

The Active Drive Faults dialog box is automatically displayed whenever a fault occurs. There are two options in this dialog box: Reset Faults and Ignore Faults.

Resetting Faults

Some drive faults are automatically reset when the fault condition is cleared. Others require drive power to be cycled or the drive to be “rebooted” to be cleared. If you wish to continue working in the PowerTools software without resetting the fault, click the *Ignore Fault* button.

To reset faults that can be reset with the *Reset Faults* button, simply click the *Reset Faults* button in the Drive Faults Detected dialog box or push the Reset button on the front of the drive where the fault occurred.

Viewing Active Drive Faults

To view all active drive faults, select the View Faults command from the **Device** menu. The dialog box displayed is the same as Active Drive Faults dialog box described above.

Rebooting the Drive

To reboot the drive, cycle power or select the Reboot Drive command from the **Device** menu. This command reboots the drive attached to the active Configuration Window.

Error Messages

Error Messages (FM-1, FM-2)

PowerTools-FM will pop-up an error message box to alert you to any errors it encounters. These message boxes will describe the error and offer a possible solution.

The table below list the of common problems you might encounter when working with PowerTools-FM software along with the error message displayed, the most likely cause and solution.

Problem/Message	Cause	Solution
Time-out while waiting for device response. The attempted operation has been cancelled. (see fault: No device selected)	Loss of serial communications.	Check the serial connection to the device and try operation again.
The attached device(s) do not have valid revisions, or do not have matching revisions.	Attempting to broadcast to drive without matching firmware revisions.	Program each drive individually.
Unable to communicate with device [Address x]	The device that you are attempting to communicate with is no longer available.	Check all connections and verify that you are using the correct baud rate then try again.
The specified drive type (name) does not match the actual drive type (name). Please make necessary corrections.	The drive type you selected in the "Drive Type" list box does not match the drive you are downloading to.	Change the drive type selected in the "Drive Type" list box to match the drive you are downloading to.
Non-Control-Techniques device attached (address). When trying to program more than one drive, only EMC drives of the same type can be attached to the network.	This error is caused When you attempting to perform an upload or download to multiple drives and one or more of the drives are not the same type.	Disconnect the device(s) that has been specified and try the operation again or program each device individually.
You have changed a parameter which will not take effect until the drive has been rebooted. Before you reboot the drive, you will need to save your setup to NVM. Do you wish to save your setup to drive NVM now?	See message.	Yes/No.
(Operation Name) The attempted operation has been cancelled.	Communication error.	Retry operation. Check connection to drive.
Invalid entry. The entry exceeds the precision allowed by this field. The finest resolution this field accepts is (value).	Entered a value out of range.	Enter a value within the range of that field. The status bar displays information on the currently selected object or action.
The device was disconnected during the upload. The upload was not complete.	Connection to the device was lost (a time-out occurred).	Check the connection to the device and try again.
The device was disconnected during the download. The download was not complete.	Connection to the device was lost (a time-out occurred).	Check the connection to the device and try again.
No device selected.	The device you are attempting to communicate with is not responding.	Check all connections. Verify the baudrate. Verify that the "Maximum Node Address" value is at least the value of the address of the drive connected.

Error Messages (FM-3, FM-3DN, FM-3E, FM-3PB, FM-4, FM-4DN, FM-4E, FM-4PB)

PowerTools Pro will pop-up an error message box to alert you to any errors it encounters. These message boxes will describe the error and offer a possible solution.

The terms below appear in the list the of common problems you might encounter when working with PowerTools software along with the error message displayed, the most likely cause and solution.

Assign means to set a value using an equation. For example, $x = 2$, you are assigning the value of 2 to x.

A **Boolean value** is a value that represents two states such as On or Off. In the FM-,3 there are three variable types that have Boolean values. They are Boolean Variables, Input Event Variables and Output Event Variables. They all have a Boolean Value and can be used in equations to assign their Boolean value to another variable or in a conditional test.

In an equation, conditional tests such as $(vel > 3.1)$ become Boolean values.

In FM-3/FM-4 Programming, unquoted text names are used to represent Boolean constants. Several different names are available. They all represent the two Boolean states and therefore are interchangeable.

An **Expression** is a collection of mathematical operands (variables, constants and numbers) and operators(+, -, *, <, >, etc) that form a value. The right hand side of an equation (to the right of the =) is an expression.

The **Parser** is an internal component of PowerTools software that reads your program text file and generates executable code used by the FM-3/FM-4 Module firmware. The parser detects errors that are reported to you as Red Dot Error Messages.

Your program errors are displayed in the program view in **Red Dot Error Messages**. They are indicated with red dots. To get further information on the cause of the error you use the programming tool bar's red dotted question mark. This is an on/off setting that enables error message displays and application help messages.

Non-Programming Error Messages (FM-3, FM-3DN, FM-3E, FM-3PB, FM-4, FM-4DN, FM-4E, FM-4PB)

These messages occur while you are working in a view other than the Program View. The Program View has error messages specific to it, and they are described in a Programming Error Messages section. The Popup messages are listed below.

Can Not Add Index, until current is valid.,
Can Not Add Jog, until current is valid.,
Can Not Add Program, until current is valid.

The current View must be valid before you can create a new instance of Index, Jog or Home.

Error: The maximum limit of Instances is reached.

The number of Index instances, Jog Instances and Home Instances is limited. If you attempt to add an instance and the number of existing instances is at the maximum, you will get this message.

Programming Error Messages (FM-3, FM-3DN, FM-3E, FM-3PB, FM-4, FM-4DN, FM-4E, FM-4PB)

These Red Dot Error messages occur while you are working in the Program View.

When creating a program, the parser is executed when you left mouse click, when you arrow off the current Line, when you enter the carriage return, when you paste or when you drop a drag source. The parser detects errors and marks the line with a "Red Dot". To get further information on the cause of the error you use the programming tool bar's red dotted question mark. This is an on/off setting that enables error message displays and application help messages.

Problem/Message	Cause	Solution
Your Application is not valid to download ...	There are errors such as "Red Dot" errors in one or more programs that prevent the program from being downloaded to the module.	The message will provide more information such as which program is invalid to help the user correct the problem.
Your Application has ...	There are errors such as "Red Dot" errors in one or more programs. The operation (i.e. file save) was completed, however other operations such as download would fail for this application.	The message will provide more information such as which program is invalid to help the user correct the problem.
A FM-3/FM-4 number's decimal Point resolution can not be greater than ten	The FM-3/FM-4 does not use standard floating point. It uses Integer arithmetic to prevent round off errors. Decimals are used, but decimal point position is handled separately from the integer value. Zero puts the decimal point to the far right. Ten puts the decimal point at the far left.	The decimal point position must be between zero and ten.
A FM-3/FM-4 number's mantissa must be between -2147483647 and 2147483647	The mantissa must be between -2147483648 and 214748364.	The decimal point position must be between zero and ten.
A numeric variable can only be assigned a numeric value	The Variable is a numeric. It only accepts types consisting of numeric values.	
A string variable can only be assigned a quoted text string	The Variable is string. It only accepts types consisting of text strings.	
Can only compare(>,<,etc) numeric results	This message occurs in conditional Expressions (i.e. If then). Variables are type identified, so equation and assignments ($x = 9$) can be verified. In an expression only numerical values can be compared for greater than and less than conditions.	
Could not find the variable	See message.	
Could not find the variable defined by program text	See message.	
Destination Event variables can only be assigned an Event or Boolean	The Variable is an Input event. It only accepts types consisting of Boolean, and events.	
Program Instance does not Exist	You attempted the "Call Program.#", but the program does not exist.	
Single value expressions can only be Boolean constants, Events or Boolean variables	This message occurs in conditional Expressions (i.e. If then). Variables are type identified, so equation and assignments ($x = 9$) can be verified.	In an expression you can use single variables without a comparison, but, then they must be a Boolean constants, Events or Boolean variable.

Problem/Message	Cause	Solution
String does not represent a predefined name...	The string needs to match one of the defined strings on record in the FM-3/FM-4 Registry data base.	
String is not a selection	The string matches one of the defined strings, but that string is not a selection.	
Syntax error encountered	Parser Error Message. The Parser can not understand your text sequence.	
Text Strings are limited to 12 characters...	To change a Name you assign a quoted text string to that name. In FM-3/FM-4, text strings are fixed at 12 characters. If you use fewer than 12 characters, blanks are automatically inserted. An error occurs if you attempt to use more than 12 characters.	
The Boolean variables can only be assigned an Event or Boolean value	The Variable only accepts types consisting of Boolean, and events.	
The destination variable does not accept Data	The Variable's internal data type attribute was not found.	
The destination variable does not accept negative numbers	You attempted to assign a negative number to an unassigned variable .	
The destination variable is Read Only	This message occurs when trying to assign a value to a read only variable.	
The destination variable only accepts a numeric value	See message.	
The destination variable only accepts a Boolean or Event value	See message.	
The destination variable only accepts quoted "text"	See message.	
The destination variable only accepts selection text	See message.	
The destination variable's resolution is less than the resolution of the number	You attempted to assign a number with a greater resolution of decimal points than the variable will accept (ie index.0.vel = 2.34567).	The User Units setup will allow you to define the desired decimal point resolution.
The number is outside the range of the destination variable	You attempted to assign a number that is outside the variable's range.	To determine the range comment out this instruction and use the red dot help on the variable.
The mix of variable or expressions types can not be added or subtracted	This message occurs in equations. Variables are type identified, so equation and assignments (x = 9) can be verified. In an equation only numerical values can be multiplied or divided. Booleans, Selections, text and events can not be added.	
The mix of variable or expressions types can not be compared(=)	This message occurs in conditional Expressions (i.e. If then). Variables are type identified, so equation and assignments (x = 9) can be verified. In an expression numerical, Boolean and event values can be compared for equality conditions. Selections and text can not be used.	
The mix of variable or expression types can not be multiplied or divided	This message occurs in equations. Variables are type identified, so equation and assignments (x = 9) can be verified. In an equation only numerical values can be multiplied or divided. Booleans, Selections, text and events can not be compared.	

Problem/Message	Cause	Solution
The Source Event- <variable name> can only be assigned <max number> times	The limits to Source Event assignments are the number of destinations assigned to a single Output event is limited. Generally this is three. For Selections it is one. The Waitfor Instruction temporarily assigns its Output Event Operands. This is subject to the assignment limitations.	To use an Output Event in a waitfor instruction, there must be at least one free assignment.
The Selection variable can only be assigned a Selection value	The destination variable only accepts selection values. Selection values are fixed unquoted text. The selection text must exactly match the available selections of the Destination variable.	
This instance does not exist	This variable is referencing an instance that has not been created in your application. For example "Index.9.vel" the instance 9 of index has not been defined.	
This is not a fully qualified variable	To use a variable it must be fully defined. Some variables are global variables and only the name is defined. Other Variables require a name.name convention. Other variables require an instance number (index.1.vel). All the components identifying the variable must be available to qualify the variable.	
This variable cannot be assigned a selection value	The variable that you are attempting to define with a selection does not accept selection values.	
This variable type cannot be assigned a value	The Variable is of a type that does not accept any assignments. A Source Event variable is an example. You can not assign a value to an output event.	
The selection is not valid for this variable	The variable that you are attempting to define with a selection does accept selection values. However the selection you are attempting to use is not accepted by this variable.	
Trying to assign a selection variable with bad selection data	When checking to see if the selection goes with the destination variable, the source is not a defined selection for the destination variable.	

Online Status Indicators

Watch Window (PowerTools-FM)

This feature allows you to customize a window to monitor drive parameters which you select from a complete list of drive parameters. From this window you can watch the parameters you selected in real time. This feature is only available when you are online with the drive.

Note

You cannot change the values of the parameters while they are being displayed in the Watch Window. The parameter in the setup screens will look like they have been changed when they actually have not.

Note

It is normal to have the Watch Window show up with the three motor parameters already selected. If you do not need to view them, simply push the *Clear All* button and select the parameters you wish to view.

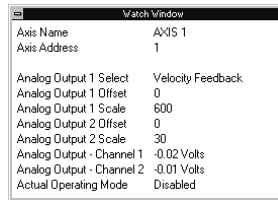

Figure 21: Watch Window

Note

Parameters selected and displayed in the Watch Window cannot be updated from the tabs. To update a parameter, delete it from the Watch Window selection.

The Watch Window is accessed by selecting Watch Drive Parameters from the **Tools** menu or by clicking on the Watch Window icon on the toolbar.

The Watch Window will automatically appear as soon as you select a parameter from the Select Drive Parameters dialog box. After you have selected the parameters you wish to watch, click the *Close* button. The Select Drive Parameters dialog box will close and the Watch Window will remain open.

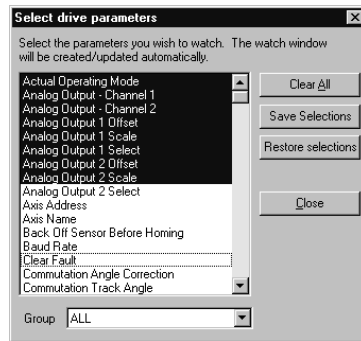

Figure 22: Select Drive Parameters Dialog Box

Select Drive Parameters Dialog Box

This list box enables you to view the complete list of parameters or just a group of parameters you are interested in. The groups include: Analog Out, Communication, Digital Inputs, Digital Outputs, Fault Counts, Fault Log, Home, ID, Input Functions, Jog, Motion Commands, Motor, Output Functions, Position, Setup, Status, Torque, Tuning, User Defined Motor, Velocity.

Clear All Button

This button is used to clear all the parameter selections that were previously selected.

Save Selections Button

This button saves the parameter selections. This enables you to restore the same list of parameters for use in future online sessions.

Restore Selections Button

This button restores the parameter selections previously saved. This enables you to restore the list of parameters you created in a previous online session.

Watch Window (PowerTools Pro)

Power Tools Pro contains a diagnostic utility called the Watch Window. The Watch Window can be used while Power Tools Pro is running and the PC is online with the FM-3/4 module. The Watch Window allows the user to monitor the status of all their desired system parameters in one location. An example of the Watch Window is found in Figure 23 below.

To setup the Watch Window, select Tools>Watch Window from the Power Tools Pro menu bar. If not online with the module, Watch Window will be unavailable on the menu. Upon selecting Watch Window, the following window will appear.

Watch Window	
Axis Name	Axis 1
Axis Address	1
PosnCommand	0.00degrees
PosnFeedback	0.00degrees
FollowingError	0.00degrees
PosnFeedbackInCounts	0Counts
VelCommand	0degrees/m
VelFeedback	0degrees/m
TorqueCommand	0.0% Cont
TorqueCommandLimited	0.0% Cont
FoldbackRMS	0.0% Cont.
ShuntPowerRMS	0.0%
MasterAxis.PosnFeedback	0Count
MasterAxis.PosnFeedbackInCounts	0Counts
DriveEnableStatus	False
Feedhold	False
Brake.Disengaged	False
CommandingMotion	False
AbsolutePosnValid	False
InPosn	False
AtVel	False
PowerStageEnabled	False
FoldbackActive	False
ShuntActive	False
TorqueLevelActive	False
TorqueLimitActive	False

Figure 23: Watch Window

The Select Drive Parameters window as seen in Figure 24 allows the user to specify which parameters are to be seen in the Watch Window. To select a parameter for the Watch Window, simply click once on the parameter and it will be added to the Watch Window. The parameters already in the Watch Window will be highlighted in the Select Drive Parameters window.

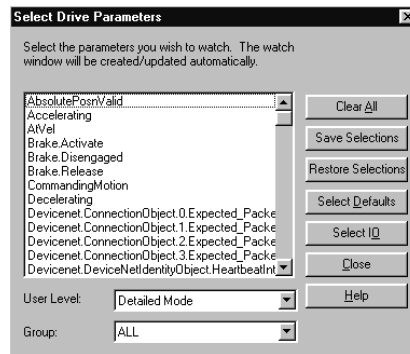

Figure 24: Select Drive Parameters Dialog Box

Once a parameter is added to the Watch Window, its current value or state is constantly monitored. If a parameter in the window changes value or state, it will change to a red color. It will remain red until it hasn't changed for a period of 4 seconds. After 4 seconds, the parameter will turn back to black in color. This allows the user to see what has changed recently without looking directly at every parameter.

The following are descriptions of the buttons and controls on the Select Drive Parameters window:

Clear All – By clicking on the Clear All button, all of the parameters in the Watch Window will be erased.

Save Selections – By clicking on Save Selections, the user can save the specific parameters that have been added to the Watch Window. Once the selections have been saved, the Restore Selections button can be used to monitor all the same parameters the next time the user opens the Watch Window. Therefore, if there is a list of helpful diagnostic parameters the user wishes to see when online, those specific parameters can be saved and recalled in the Watch Window at any time. The settings are saved in a file named “fm3watch.wch”.

Restore Selections – By clicking on the Restore Selections button, the Watch Window will be filled with the list of parameters that were last saved using the Save Selections button.

Select Defaults – The Select Defaults button adds the most commonly used parameters to the Watch Window.

Select I/O – The Select I/O button will add the Drive and Module digital inputs and outputs to the Watch Window.

Close – The Close button will close the Select Drive Parameters window, while the Watch Window will remain open.

Help – The help button will give associated help on the Watch Window setup.

User Level - The User Level setting is a filter for the parameters that are seen in the Select Drive Parameters list. If set to Easy, the parameters used in most basic applications will be seen while the more advanced parameters are hidden. If set to Detailed, the parameters used in more advanced applications will be added to the list. If set to Too Much, then all parameters available in the system will be seen in the list. This allows the user to select the User Level they are most comfortable with to avoid confusion. If a parameter has been selected and the User Level is changed, then the selected parameter will remain selected.

Group - The Group setting allows the user to filter the parameters that are displayed in the Select Drive Parameters window by group. The Group defaults to “ALL” so that parameters from all groups are seen. If the user wishes to only see those parameters from a specific group, the click on the Group list box and select the group of parameters they wish to see.

Global Where Am I Button (PowerTools Pro)

The Program View, when online and executing a program or sequence of programs, can display current program status. Pressing the Where Am I button on the PowerTools Pro toolbar creates a blue triangle that appears on the line of the program currently being executed.

The Global Where Am I can be used for diagnostics. When the user needs to know where in a complicated program the drive is or when the user wishes to follow the logical flow of the program.

Motion Status (PowerTools Pro)

While the drive is online, the name of the program currently running or the motion type currently running will appear in the status bar at the bottom left corner of the PowerTools Pro screen.

Specifications (All FMs)

Ambient temperature range for rated output: 32°F to 104°F (0°C to 40°C)

Maximum ambient operating temperature: 104°F to 122°F (40°C to 50°C) with power derating of 3%/°C

Rated altitude: 3,280 feet (1000 m)

Vibration: 10 to 2000 Hz at 2g

Humidity requirement: 10 to 95% non-condensing

Storage temperature: -13 °F to 167 °F (-25 °C to 75 °C)

Approximate Weight: 0.40 lbs (0.18 kg)

Power consumption: 3 W from EN drive power supply.

I/O Supply Voltage: +10 Vdc to +30 Vdc.

Function		Electrical Characteristics
Inputs	ON State Voltage	+10 Vdc to +30 Vdc
	ON State Current	2 mA to 6.5 mA
	OFF State Voltage	0 to 3 Vdc
	OFF State Current	0 to 400 μ A
Outputs	Max. ON State Voltage	I/O Supply Voltage -1.5 V
	Max. ON State Current	150 mA
	Max. OFF State Current	100 μ A

Dimensions and Clearances

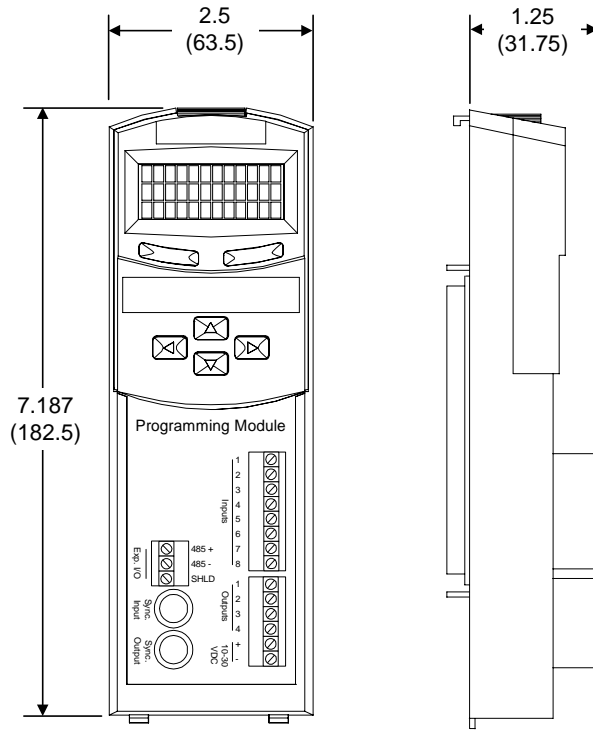

Figure 25: Typical Dimensions of FM Module (FM-3 Module shown)

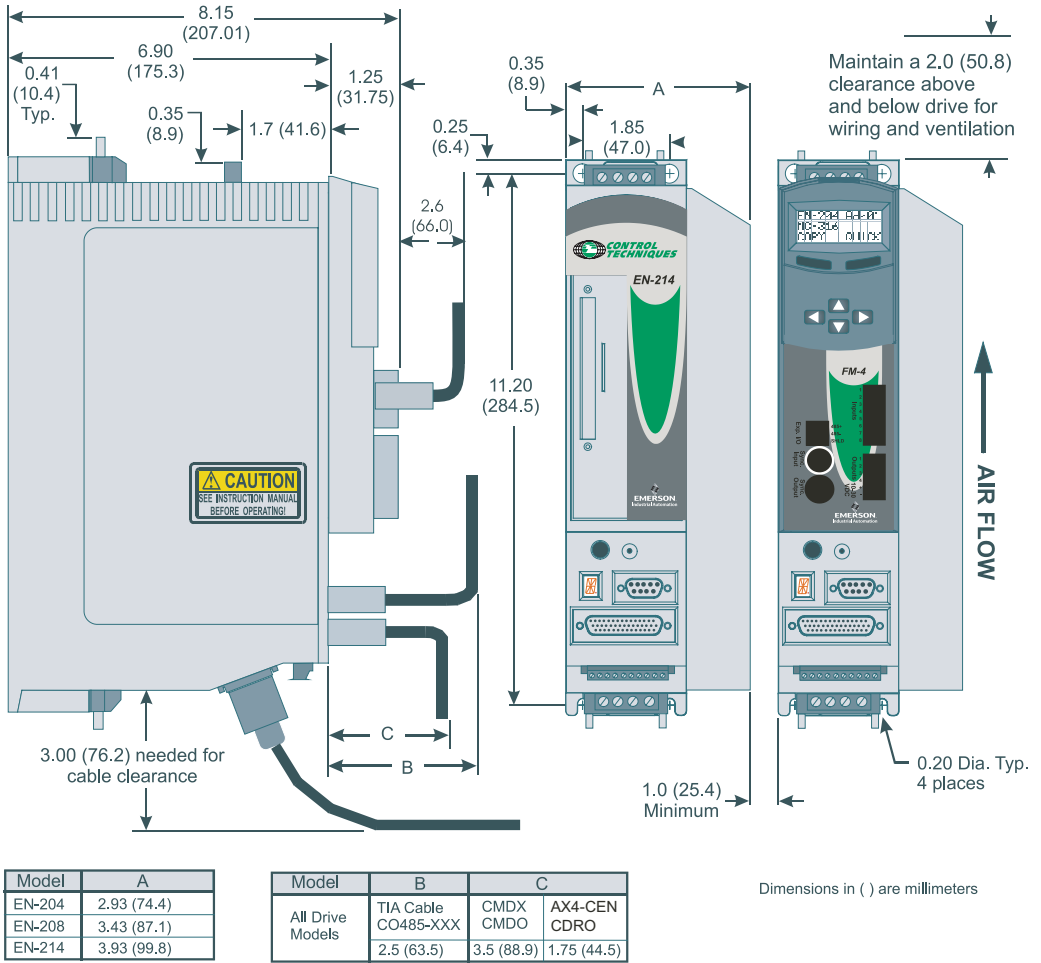
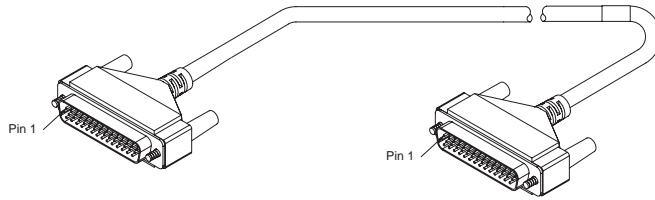

Figure 26: FM Module Installed (FM-4 shown)

Cable Diagrams

Drive Signal	CMDX, CMDO, ECI-44	CDRO	AX4-CEN
Analog In +	X	X	X
Analog In -	X	X	X
Encoder Out A	X	X	X
Encoder Out A/	X	X	X
Encoder Out B	X	X	X
Encoder Out B/	X	X	X
Encoder Out Z	X	X	X
Encoder Out Z/	X	X	X
Pulse In A	X	X	
Pulse In A/	X	X	
Pulse In B	X	X	
Pulse In B/	X	X	
Pulse In Z	X		
Pulse In Z/	X		
Pulse In A (single ended)	X		X
Pulse In B (single ended)	X		X
I/O Input Drive Enable	X	X	X
I/O Input #1	X		
I/O Input #2	X		
I/O Input #3	X		
I/O Input #4	X	X	X
I/O Output #1	X	X	X
I/O Output #2	X	X	X
I/O Output #3	X	X	X
I/O Power + In (1st wire)	X	X	X
I/O Power + In (2nd wire)	X	X	X
I/O Power 0 V In (1st wire)	X	X	X
I/O Power 0 V In (2nd wire)	X		
Analog Out 0V	X	X	X
Analog Out #1 +	X	X	X
Analog Out #2 +	X	X	X
External Encoder +5 Power Out (200 mA)	X	X	X
+15 V Power Out (10 mA)	X		
RS-485 +	X		
RS-485 -	X		

CMDX-XXX Cable



Note: Inner foil shields are already mechanical connected to outer braid shield by raw cable manufacture.

1	RED/BRN		1	Input I/O 1
2	BRN/RED	-P	2	Input I/O 2
3	BLK/BLU		3	Input I/O 3
4	BLU/BLK	-P	4	Input I/O 4
6	WHT/ORG		6	RS-485+ } See Note below
21	ORG/WHT	-P	21	RS-485- }
8	PUR/BLU		8	Motor Encoder Output A
9	BLU/PUR	-P	9	Motor Encoder Output A/
11	RED/BLU		11	Ext Encoder 200 mA max +5 V
12	BLU/RED	-P	12	Ext Encoder 200 mA max Common
16	BLK/GRN		16	Drive Enable Input
17	GRN/BLK	-P	17	Output I/O 3
18	BLK/BRN		18	Output I/O 2
19	BRN/BLK	-P	19	Output I/O 1
23	PUR/ORG		23	Motor Encoder Output B
24	ORG/PUR	-P	24	Motor Encoder Output B/
25	BLK/RED		25	Sync Encoder Input Z
39	RED/BLK	-P	39	Sync Encoder Input Z/
27	PUR/GRN		27	Sync Encoder Input A
41	GRN/PUR	-P	41	Sync Encoder Input A/
34	YEL/BLU		34	24V I/O
32	BLU/YEL	-P	32	OV I/O
33	YEL/BRN		33	24V I/O
31	BRN/YEL	-P	31	OV I/O
37	PUR/BRN		37	Motor Encoder Output Z
38	BRN/PUR	-P	38	Motor Encoder Output Z/
40	PUR/GRY		40	Sync Encoder Input B/
26	GRY/PUR	-P	26	Sync Encoder Input B
14	WHT/BLU		14	Command Input-
15	BLU/WHT	-P	15	Command Input+
29	WHT/RED		29	Analog out AG 1 and 2
28	RED/WHT	-P	28	ENV+
43	WHT/GRN		43	Analog out 1+
44	GRN/WHT	-P	44	Analog out 2+
20	YEL/GRY		20	Not Used
36	GRY/YEL	-P	36	Not Used
	Drain Wires			

Note

Some CMDX cables may have White/Yellow and Yellow/White wires in place of the White/Orange and Orange/White shown in the figure above (pins 6 and 21).

CMDO-XXX Cable

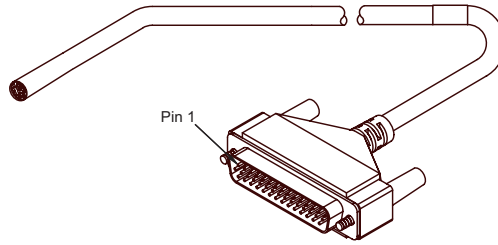

Note: Inner foil shields are already mechanical connected to outer braid shield by raw cable manufacture.

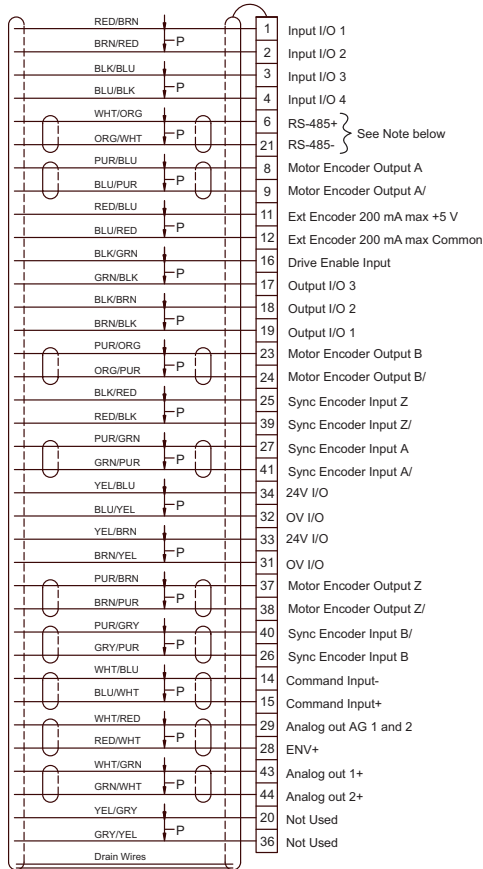

Note

Some CMDO cables may have White/Yellow and Yellow/White wires in place of the White/Orange and Orange/White shown in the figure above (pins 6 and 21).

CDRO-XXX Cable

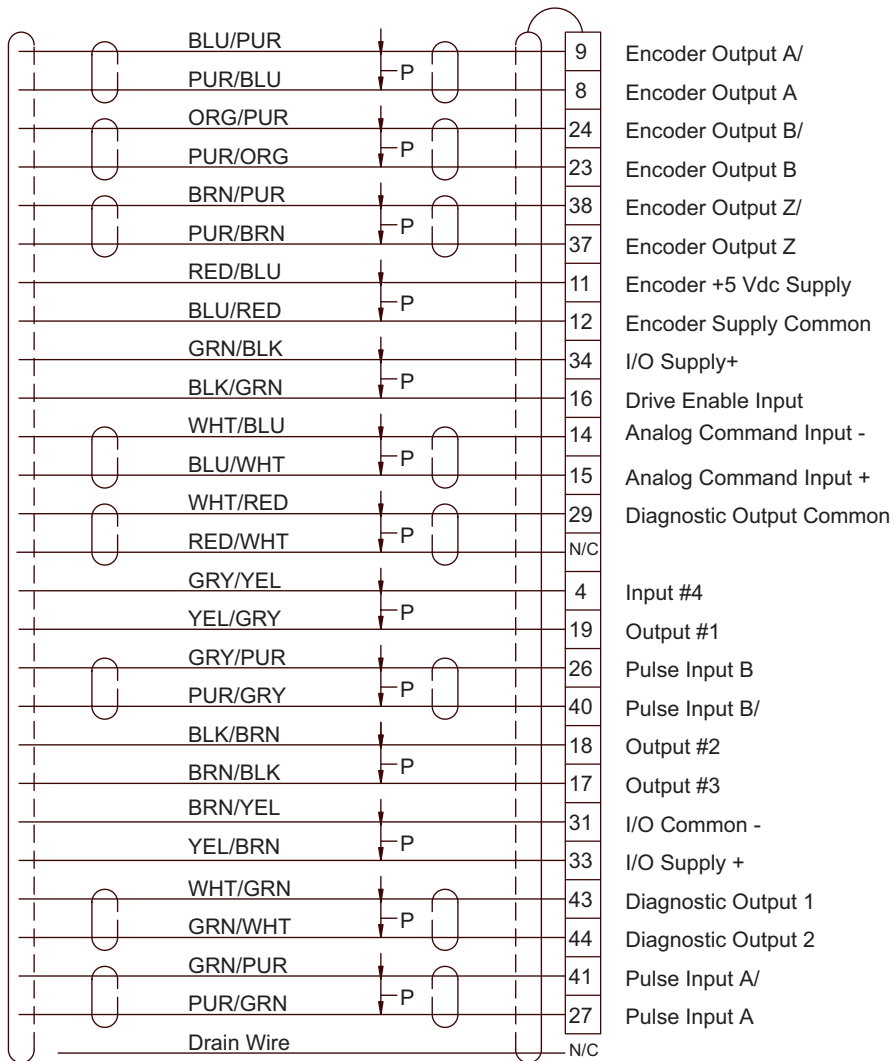
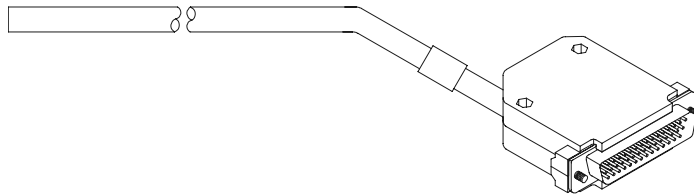

TIA-XXX Cable

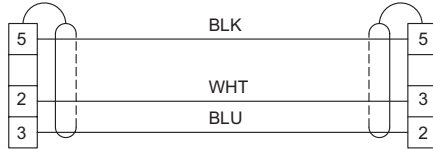
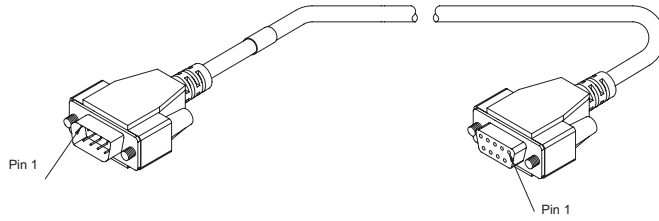

DDS-XXX Cable

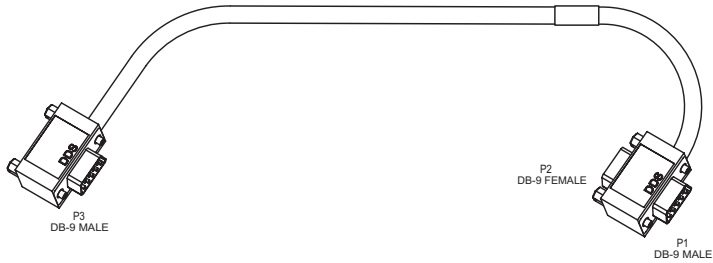

WIRING DIAGRAM

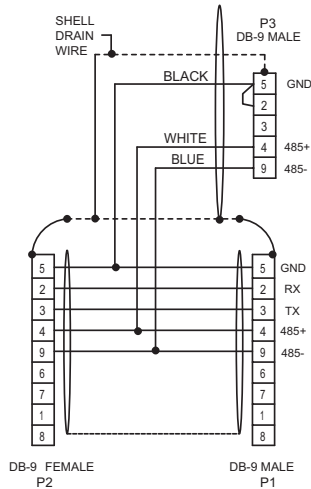

TERM-H (Head) Terminator

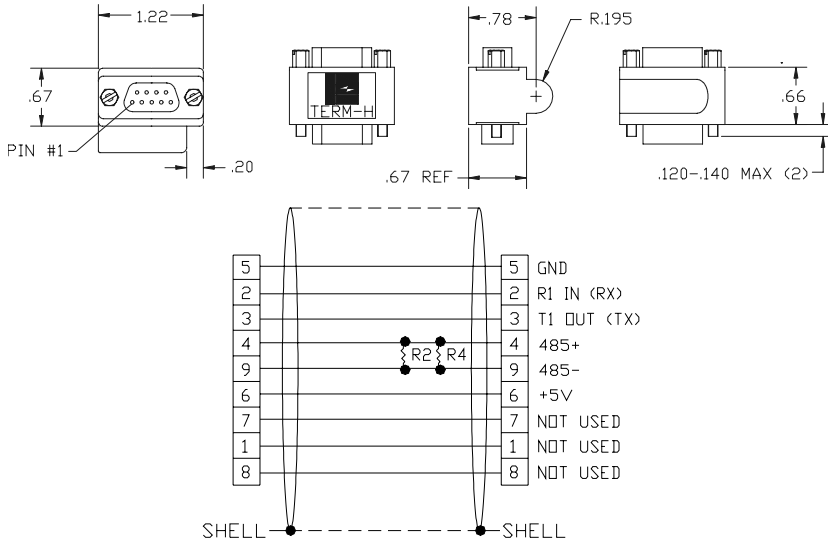

TERM-T (Tail) Terminator

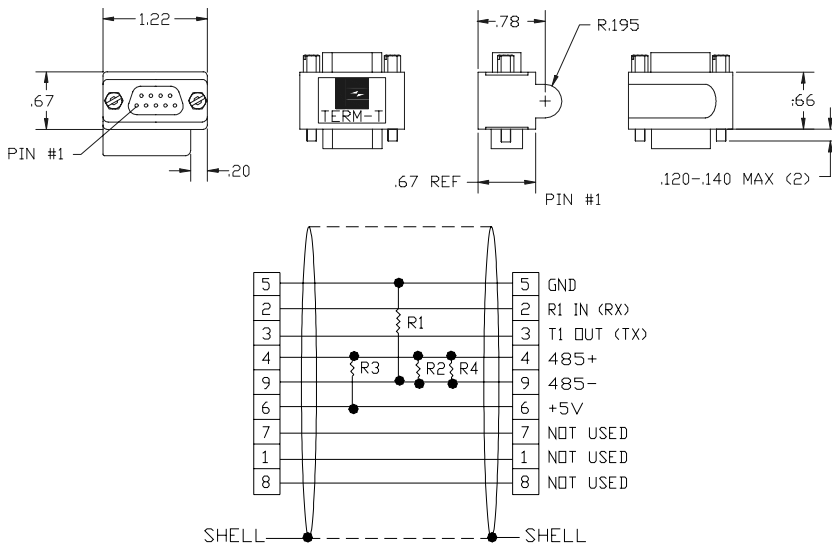

Note

See the "Multi-drop Communications" section in the particular FM Module's reference manual for resistor values.

CMDS-XXX Cable

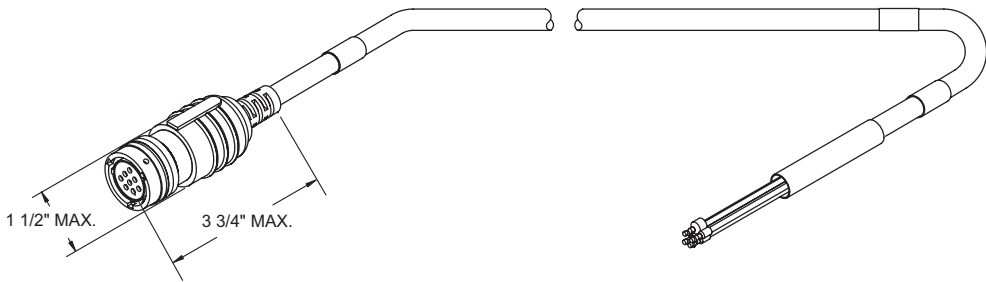

CMMS-XXX Cable

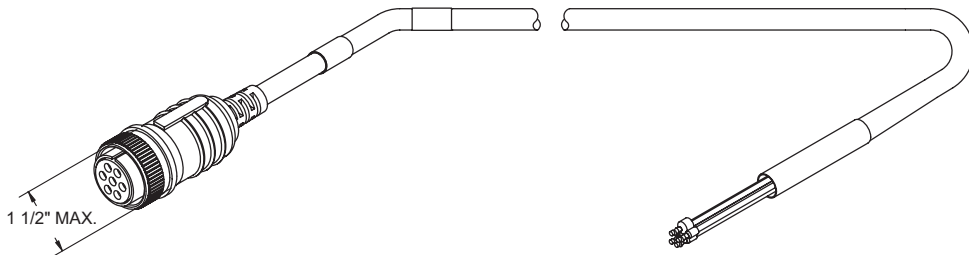

CFCS-XXX Cable

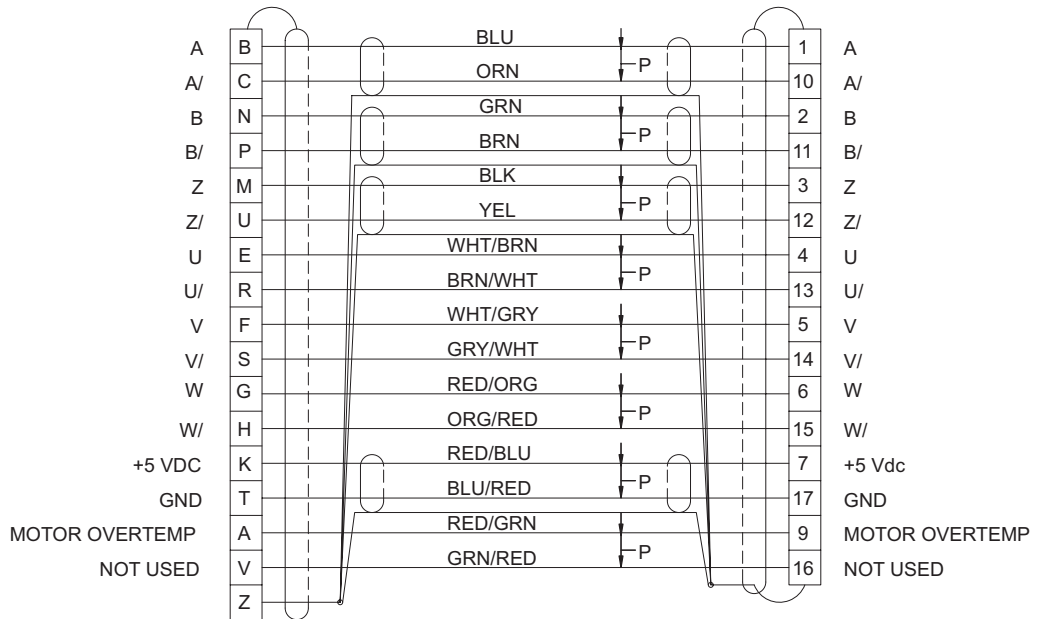
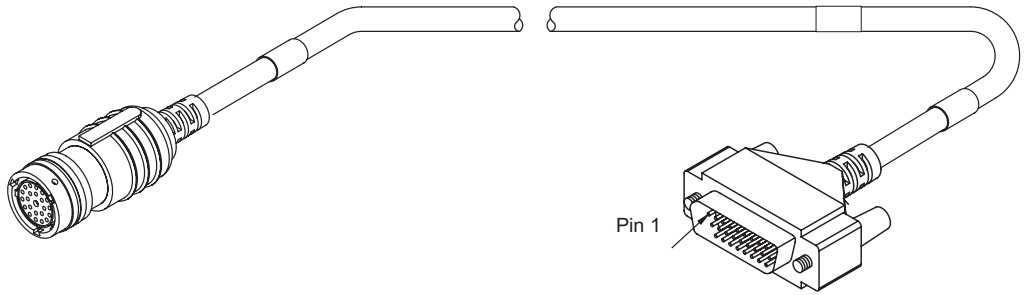

CFCO-XXX Cable

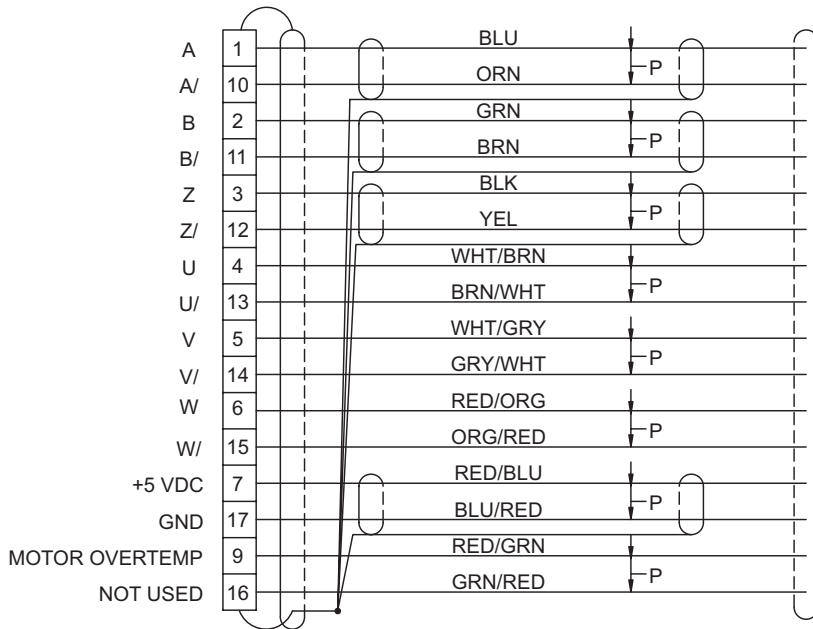

CFOS-XXX Cable

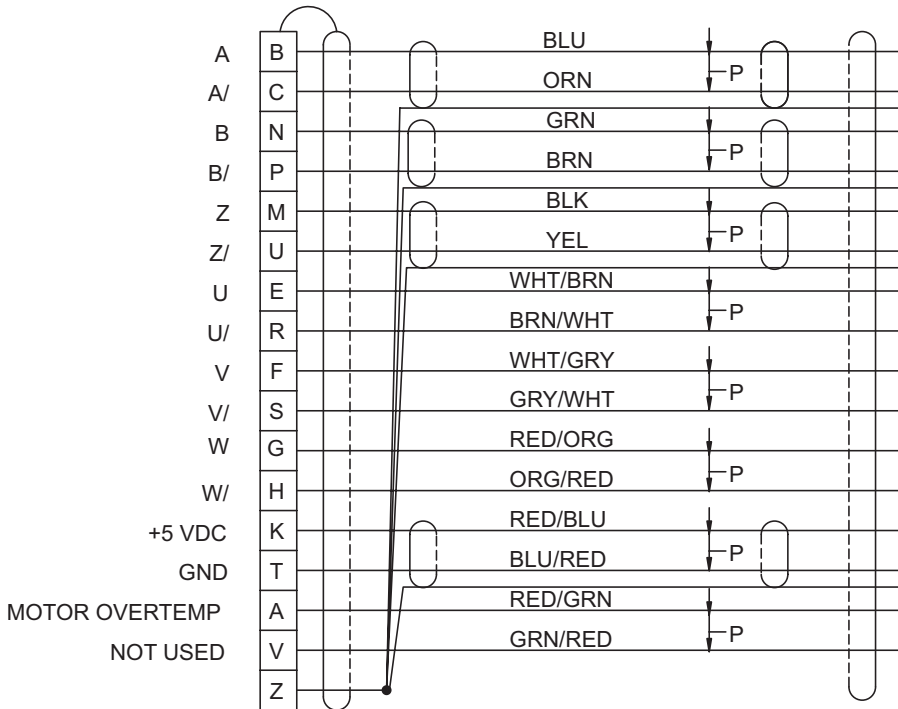
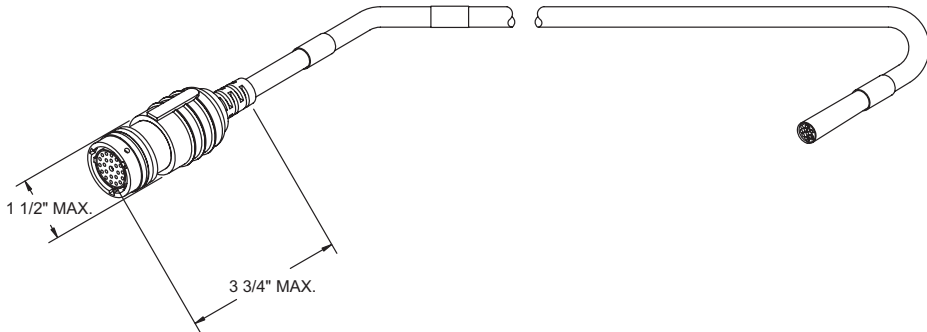

Sync Cable Diagrams (All FM-3 and FM-4 Models)

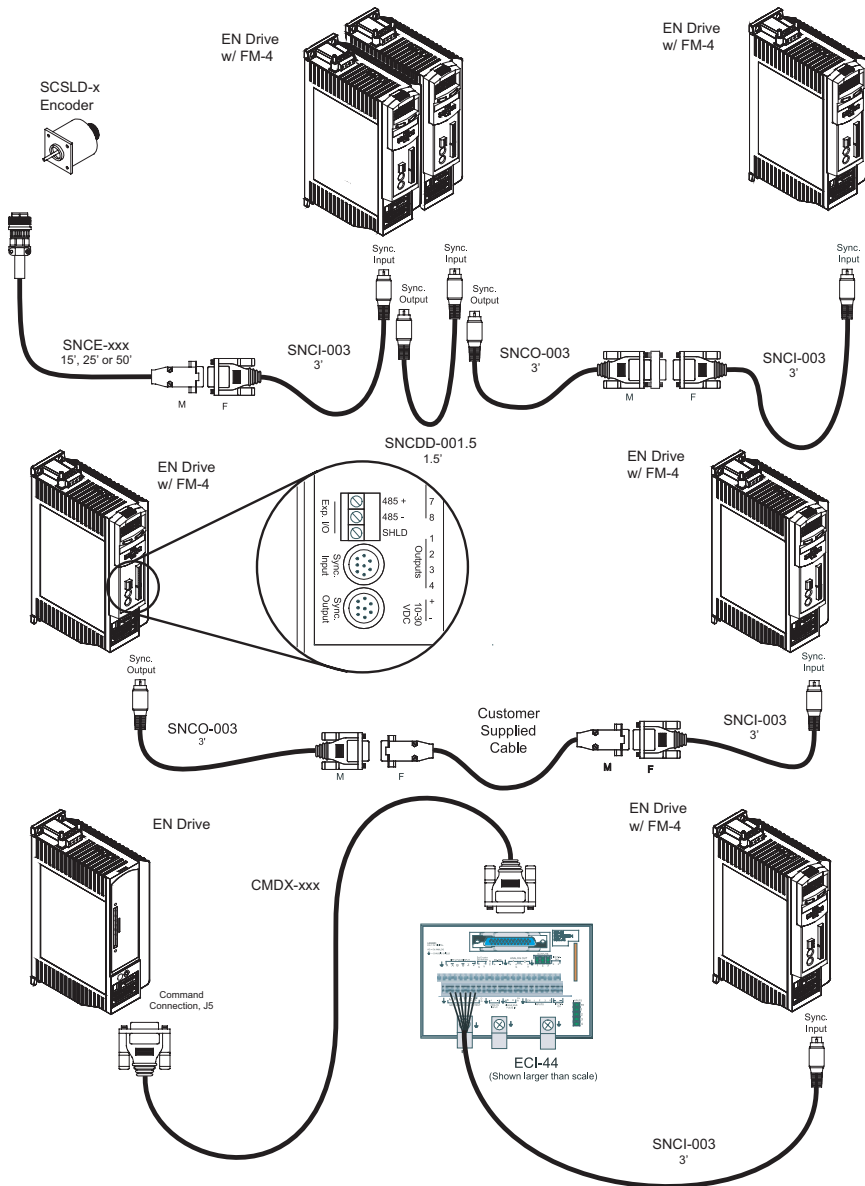
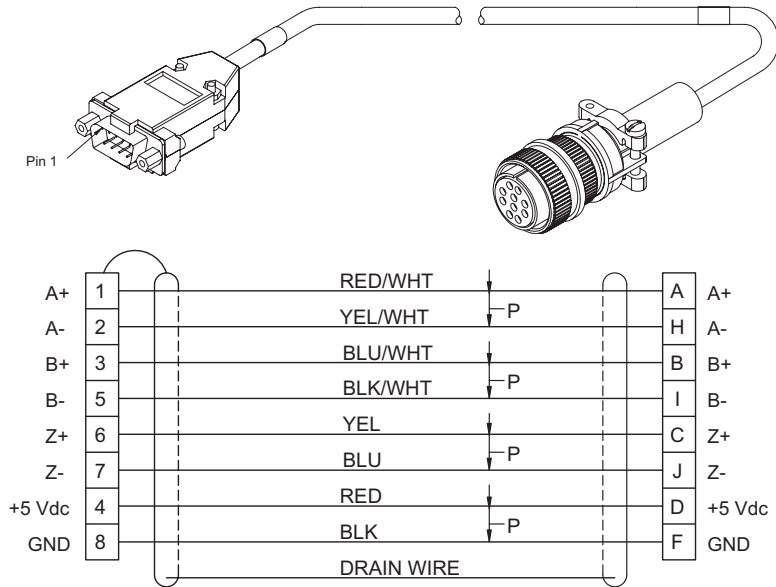
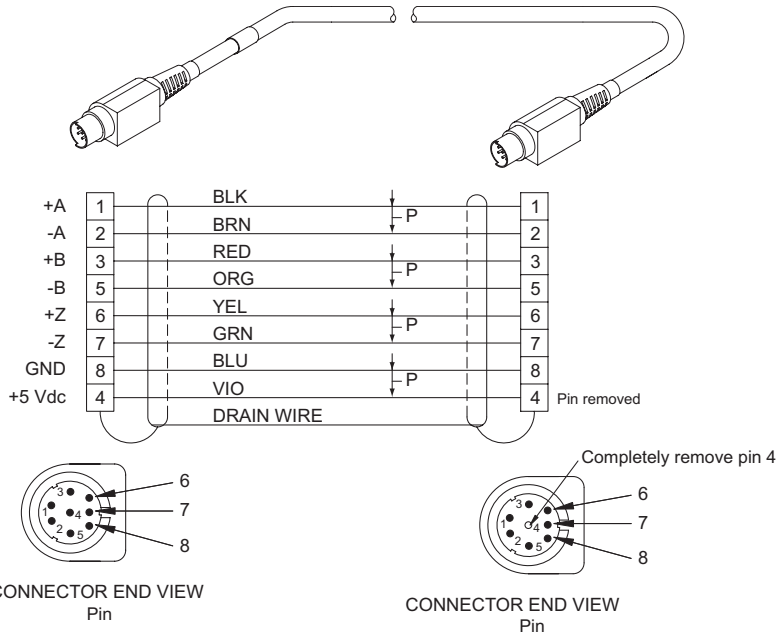

Figure 27: Sync Cable Connections and Options (FM-4 shown)

SNCE-XXX Cable



SNRDD-001.5 Cable



SNCO-003 Cable

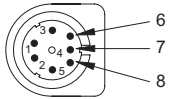
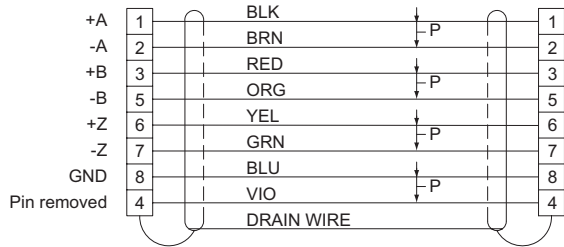
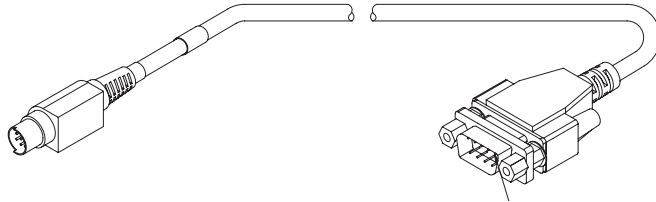

CONNECTOR END VIEW

SNCI-003 Cable

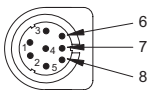
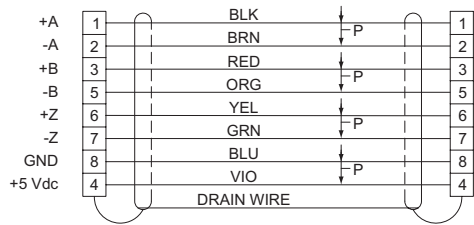
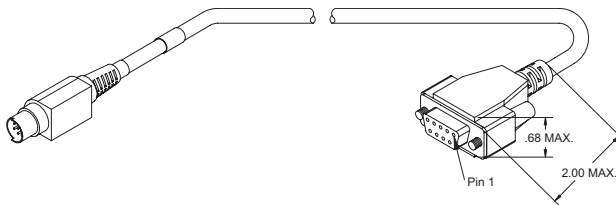

CONNECTOR END VIEW
Pin

SNCLI-003 Cable

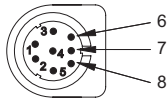
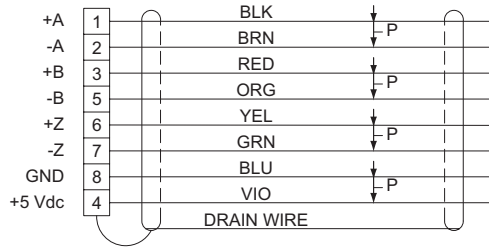
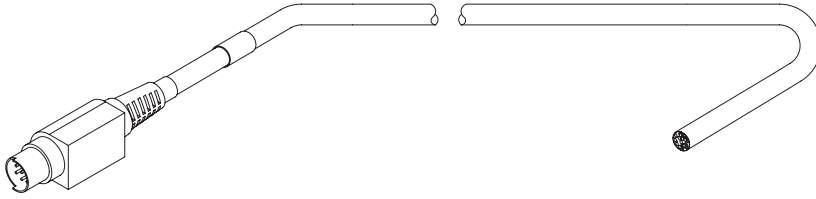

CONNECTOR END VIEW
Pin

Symbols

+/- Limit, 33

A

All "On", 33
Analog Output, 34

B

Brake Operation and Wiring, 34

C

Cable Diagrams, 48
CDRO-XXX Cable, 51
CFCO-XXX Cable, 56
CFCS-XXX Cable, 55
CFOS-XXX Cable, 57
CMDO-XXX Cable, 50
CMDS-XXX Cable, 54
CMDX-XXX Cable, 49
CMMS-XXX Cable, 54

D

DDS-XXX Cable, 52
Diagnostic Display, 27
Dimensions and Clearances, 46
Drive Faults, 34

E

Encoder Line Fault, 32
Encoder State, 32
Error Messages, 35

F

Fault Codes, 28
Fault Descriptions, 31
Firmware Checksum, 31
FM-2 Indexing Module Installation
 Electrical Installation, 8
Following Error Fault, 33

H

High DC Bus Fault, 32

I

Installation Notes, 7, 15, 23
Introduction, 1, 19
Invalid Configuration, 31, 33, 34

L

Low DC Bus Fault, 32

M

Modbus Communications, 10

Motor Over Temperature Fault, 32

N

Non-volatile Memory Invalid, 31

O

Over Speed Fault, 33

P

Power Stage Fault, 32

Power-Up Self-Test Failure, 31

Programming Error Messages, 37

R

RMS Shunt Power Fault, 33

S

Safety Considerations, vii

Safety of Machinery, vii

Safety Precautions, vii

Setup, Commissioning and Maintenance, vii

SNCCD-001.5 Cable, 59

SNCE-XX Cable, 59

SNCI-003 Cable, 60

SNCLI-003 Cable, 61

SNCO-003 Cable, 60

status codes

 decimal point, 27

 Ready, 27

 Ready to Run, 27

Sync Cable Diagram, 58

T

TERM-H (Head) Terminator, 53

TERM-T (Tail) Terminator, 53

TIA-XXX Cable, 52

Since 1979, the “Motion Made Easy” products, designed and manufactured in Minnesota U.S.A., are renowned in the motion control industry for their ease of use, reliability and high performance.

For more information about Control Techniques “Motion Made Easy” products and services, call (800) 893-2321 or contact our website at www.emersonct.com.

Control Techniques Drives, Inc
Division of EMERSON Co.
12005 Technology Drive
Eden Prairie, Minnesota 55344
U.S.A.

Customer Service

Phone: (952) 995-8000 or (800) 893-2321

Fax: (952) 995-8129

Technical Support

Phone: (952) 995-8033 or (800) 893-2321

Fax (952) 9995-8020

Printed in U.S.A.

graphics/CT3.5.tif @ 300 dpi 1
graphics/eia_BlackWhiteOnWhite.tif @ 2400 dpi 1
graphics/CT3.5.tif @ 300 dpi i
graphics/PIC3.tif @ 200 dpi v
graphics/PIC2.tif @ 200 dpi v
graphics/PIC1.tif @ 200 dpi v
graphics/PIC3.tif @ 200 dpi vi
graphics/PIC3.tif @ 200 dpi viii
graphics/Edrv&FM3 iso.wmf 2
graphics/fm2frnta.eps 3
graphics/fm4frontback.eps 3
graphics/960496-010.eps 4
graphics/1fm3frontback4A.eps 4
graphics/960509-010.eps 5
graphics/FM3 Attaching.wmf 7
graphics/PIC2.tif @ 200 dpi 7
graphics/FM3 Unattaching.wmf 8
graphics/PIC2.tif @ 200 dpi 8
graphics/en&fmwire.eps 9
graphics/start01.bmp @ 300 dpi 12
graphics/start02.bmp @ 300 dpi 12
graphics/start03a.bmp @ 150 dpi 12
graphics/ptfmbutton1.bmp @ 300 dpi 12
fm4 screens/PTProbutton.bmp @ 300 dpi 12
graphics/ptfmbutton2.bmp @ 300 dpi 12
graphics/openingfile.jpg @ 96 dpi 12
graphics/PToolsFM_Newdlgbox.gif @ 150 dpi 12
graphics/PToolsPro_Newdlgbox.gif @ 150 dpi 13
graphics/DCP_3682a.bmp @ 300 dpi 15
graphics/MultiTap.eps 16
graphics/MultiDrop.eps 17
graphics/cablepic.bmp @ 150 dpi 19
graphics/connector.wmf 20
graphics/connectorwiring.wmf 21
graphics/960496-010.eps 23
graphics/MultiTap [Converted].eps 24

graphics/little4cdr.wmf 30
graphics/DNFault.wmf 30
graphics/fm3screen.eps 31
graphics/PIC2.tif @ 200 dpi 32
graphics/watch window.bmp @ 300 dpi 40
graphics/select drive parameters.bmp @ 300 dpi 41
graphics/Watch Window 1.bmp @ 300 dpi 42
graphics/Watch Window 2.bmp @ 300 dpi 42
graphics/FM3 Dimensions.wmf 46
graphics/edrv&fmdimsa.eps 47
graphics/810708-A5_CMDXassy.eps 49
graphics/810708-A5_CMDXwire.eps 49
graphics/810709-A6_CMDOassy.eps 50
graphics/810709-A6_CMDOwire.eps 50
graphics/cdro cable.wmf 51
graphics/810710-A3_CDROwire.eps 51
graphics/810706-A5_TIAassy.eps 52
graphics/810706-A5_TIAWire.eps 52
graphics/810720-A3_DDSSassy.eps 52
graphics/810720-A3_DDswire.eps 52
graphics/term h cable.wmf 53
graphics/200110-00-A2-2D.wmf 53
graphics/term t cable.wmf 53
graphics/200110-01-A3-2D.wmf 53
graphics/810719-D3_CMDSSassy.eps 54
graphics/810719-D3_CMDSwire.eps 54
graphics/810711-000-A7-CMMSassy.eps 54
graphics/810711-000-A7-CMMSwire.eps 54
graphics/810721-000-D3_CFCSassy.eps 55
graphics/810721-000-D3_CFCSwire.eps 55
graphics/810722-A8_CFCOassy.eps 56
graphics/810722-A8_CFCOwire.eps 56
graphics/810724-D3_CFOSassy.eps 57
graphics/810724-D3_CFOSwire.eps 57
graphics/FM4 Cables.eps 58
graphics/810789-000-A4-SNCEassy.eps 59

graphics/810789-000-A4-SNCEwire.eps 59
graphics/810786-000-A2-SNCDDassy.eps 59
graphics/810786-000-A2-SNCDDwire.eps 59
graphics/810787-000-A2-SNCOassy.eps 60
graphics/810787-000-A2-SNCOwire.eps 60
graphics/810788-000-A3-SNClassy.eps 60
graphics/810788-000-A3-SNClwire.eps 60
graphics/810785-000-A2-SNCLIassy.eps 61
graphics/810785-000-A2-SNCLIwire.eps 61

